

Piccoli elementi. Grandi opere.

 TRAFILERIE  
**VAVASSORI**

LISTINO PRODOTTI

2026 | 1

# LA STORIA

Alfredo Vavassori inizia, nei primi anni '60, la produzione di reti a maglia sciolta zincata e plastificata, alla quale presto si affianca anche la commercializzazione di filo cotto e zincato, di chiodi e di una serie di articoli legati all'edilizia e alle recinzioni.

Negli anni seguenti, la continua evoluzione dell'impresa permette di affiancare alla produzione di reti anche quella di una parte di articoli che prima venivano solo commercializzati.

Una continua crescita, che ha portato a trasformare l'attività artigianale di ieri nelle attuali TRAFILERIE VAVASSORI s.r.l.

# OGGI

TRAFILERIE VAVASSORI s.r.l. producono filo trafilato, filo zincato, filo cotto nero e bianco, filo lucido in confezioni prepesate (da 5 kg sino a matassoni da 1000 kg); chiodi di tutte le misure, lucidi, zincati elettroliticamente e a caldo; filo plastificato in varie confezioni (dalle matassine da 10 metri per il "fai da te", sino ai matassoni per uso industriale da 500 kg) e rete metallica a maglia sciolta, sia zincata che plastificata.

L'intera produzione viene realizzata con macchinari all'avanguardia per garantire sempre la massima qualità.

TRAFILERIE VAVASSORI s.r.l. hanno affiancato, alla produzione, la commercializzazione di una vasta gamma di articoli per edilizia.

# CERTIFICAZIONI

TRAFILERIE VAVASSORI s.r.l. sono certificate secondo le normative UNI EN ISO 9001:2015.

Il Sistema di Gestione della Qualità è finalizzato nel miglioramento continuo delle attività aziendali adeguandole alle richieste della Clientela.

TRAFILERIE VAVASSORI s.r.l. - per dare valore aggiunto all'azienda e, di conseguenza, alla Clientela - hanno scelto di sviluppare un Sistema di Gestione della Qualità secondo la Norma ISO 9001:2015.

La qualità dei processi produttivi e dell'organizzazione aziendale, abbinata a una costante evoluzione degli strumenti operativi e alla formazione delle risorse umane, permette di garantire prodotti di "Qualità Vavassori".



SISTEMA DI GESTIONE  
QUALITÀ CERTIFICATO



UNI EN ISO 9001:2015







FILO



# FILO





## FILO COTTO NERO



Articolo	 Ø mm	 Ø mm	 kg pz.	 Conf. fascio	 kg x 100 ml	€ kg
2FC01	0,60	280	20	20	0,220	4,116
2FC02	0,70	280	20	20	0,300	3,841
2FC03	0,80	280	20	20	0,392	3,617
2FC04	0,90	280	20	20	0,496	3,244
2FC05	1,00	280	20	20	0,612	3,075
2FC06	1,10	280	20	20	0,741	2,955
2FC07	1,20	280	20	20	0,882	2,864
2FC08	1,30	280	20	20	1,035	2,790
2FC09	1,40	280	20	20	1,200	2,735
2FC10	1,50	280	20	20	1,378	2,695
2FC11	1,60	280	20	20	1,568	2,660
2FC12	1,80	560	25	20	1,984	2,651
2FC13	2,00	560	25	20	2,450	2,526
2FC14	2,20	560	25	20	2,964	2,459
2FC15	2,40	560	25	20	3,528	2,411
2FC16	2,70	560	25	20	4,465	2,354
2FC17	3,00	560	25	20	5,512	2,335
2FC18	3,50	560	25	20	7,080	2,335
2FC19	4,00	560	25	20	9,315	2,335
2FC20	4,50	560	25	20	11,852	2,335
2FC21	5,00	560	25	20	14,706	2,335
2FC22	5,50	560	25	20	17,850	2,593
2FC23	6,00	560	50	20	21,321	2,593
2FC24	6,50	560	25	20	25,088	2,592

## FILO COTTO NERO 5 KG







Articolo	 Ø mm	 Ø mm	 kg pz.	 Conf. fascio	 kg bancale	€ rotolo
2FCK12	1,80	400	5	5	1000	16,14
2FCK13	2,00	400	5	5	1000	15,01
2FCK14	2,20	400	5	5	1000	14,19
2FCK15	2,40	400	5	5	1000	13,64
2FCK16	2,70	400	5	5	1000	13,07
2FCK17	3,00	400	5	5	1000	12,69

# FILO





## FILO COTTO ZINCATO



Articolo	 Ø mm	 Ø mm	 kg pz.	 Conf. fascio	 kg x 100 ml	€ kg
2FZ01	0,60	280	10	20	0,220	4,570
2FZ02	0,70	280	10	20	0,300	4,570
2FZ03	0,80	280	10	20	0,392	4,426
2FZ04	0,90	280	10	20	0,496	4,378
2FZ05	1,00	280	10	20	0,612	4,455
2FZ06	1,10	280	10	20	0,741	4,435
2FZ07	1,20	280	10	20	0,882	4,304
2FZ08	1,30	280	10	20	1,035	4,189
2FZ09	1,40	280	10	20	1,200	4,189
2FZ10	1,50	280	10	20	1,378	3,968
2FZ11	1,60	280	10	20	1,568	2,808
2FZ12	1,80	600	25	20	1,984	2,808
2FZ13	2,00	600	25	20	2,450	2,633
2FZ14	2,20	600	25	20	2,964	2,574
2FZ15	2,40	600	25	20	3,528	2,574
2FZ16	2,70	600	25	20	4,465	2,574
2FZ17	3,00	600	25	20	5,512	2,574
2FZ18	3,50	600	25	20	7,080	2,574
2FZ19	4,00	600	25	20	9,315	2,574
2FZ20	4,50	600	25	20	11,852	2,574
2FZ21	5,00	600	25	20	14,706	2,574
2FZ22	5,50	600	25	20	17,850	su richiesta
2FZ23	6,00	600	25	20	21,321	su richiesta
2FZ24	6,50	600	25	20	25,088	su richiesta





## FILO COTTO ZINCATO 5 KG



Articolo	 Ø mm	 Ø mm	 kg pz.	 Conf. fascio	 Pz. bancale	€ rotolo
2FZK12	1,80	400	5	5	200	16,32
2FZK13	2,00	400	5	5	200	15,06
2FZK14	2,20	400	5	5	200	14,58
2FZK15	2,40	400	5	5	200	14,25
2FZK16	2,70	400	5	5	200	13,86
2FZK17	3,00	400	5	5	200	13,59





## FILO COTTO BIANCO PER ARMATURE



Articolo	N° fili	 Ø mm	 kg pz.	 kg scatola	 kg bancale	€ kg
<b>2B4X2</b>	2	0,90	0,333	20	1200	<b>3,415</b>
<b>2B4X3</b>	3	0,90	0,333	20	1200	<b>3,455</b>
<b>2B5X2</b>	2	1,00	0,333	20	1200	<b>3,281</b>
<b>2B5X3</b>	3	1,00	0,333	20	1200	<b>3,321</b>
<b>2B8X1</b>	1	1,30	0,333	20	1200	<b>3,079</b>





## FILO ZINCATO PLASTIFICATO A PESO



Articolo	 Ø mm	 Ø mm	 kg pz.	 Conf. fascio	 kg x 100 ml	€ kg
2P100170	1,00 / 1,70	500	250	1	0,810	<b>4,53</b>
2P120190	1,20 / 1,90	500	250	1	1,110	<b>4,45</b>
2P150200	1,50 / 2,00	500	15 - 250	20-1	1,566	<b>3,39</b>
2P170270	1,70 / 2,70	560	15 - 300	20-1	2,233	<b>3,33</b>
2P185260	1,85 / 2,60	560	15 - 300	20-1	2,452	<b>3,25</b>
2P200280	2,00 / 2,80	560	15 - 300	20-1	2,860	<b>3,00</b>
2P220300	2,20 / 3,00	560	15 - 300	20-1	3,410	<b>2,97</b>
2P240320	2,40 / 3,20	560	15 - 300	20-1	4,010	<b>2,99</b>
2P270340	2,70 / 3,40	560	15 - 300	20-1	4,931	<b>2,97</b>
2P300400	3,00 / 4,00	560	15 - 300	20-1	6,266	<b>2,99</b>





## FILO ZINCATO PLASTIFICATO A ROTOLO [BOBINA]



Articolo	 Ø mm	 ml	 kg pz.	 Pz. scatola	 Pz. bancale	€ cad.
2MP1727M050C	1,70 / 2,70	50	1,1170	10	400	<b>4,95</b>
2MP2231M050C	2,20 / 3,10	50	1,7460	10	400	<b>6,56</b>
2MP1017M100C	1,00 / 1,70	100	0,8110	10	400	<b>5,30</b>
2MP1219M100C	1,20 / 1,90	100	1,1110	10	400	<b>6,78</b>
2MP1520M100C	1,50 / 2,00	100	1,5660	10	400	<b>7,80</b>
2MP1727M100C	1,70 / 2,70	100	2,2330	10	400	<b>8,92</b>
2MP18531M100C	1,85 / 3,10	100	2,4520	5	240	<b>10,24</b>
2MP2231M100C	2,20 / 3,10	100	3,4730	5	240	<b>12,19</b>
2MP2432M100C	2,40 / 3,20	100	4,0100	5	240	<b>14,29</b>

## FILO COTTO PLASTIFICATO A PESO







Articolo	 Ø mm	 kg pz.	 Confezione	 kg bancale	€ kg
2MCP150200K02,5B	1,50 / 2,00	2,50	bobina	1000	<b>4,03</b>
2MCP150200K05B	1,50 / 2,00	5,00	bobina	1000	<b>4,03</b>
2MCP150200K10A	1,50 / 2,00	10,00	matassa	1000	<b>5,02</b>

# FILO





## FILO ZINCATO PLASTIFICATO A ROTOLO [MATASSA]



Articolo	 Ø mm	 ml	 kg pz.	 Pz. scatola	€ cad.
2MP1017M010	1,00 / 1,70	10	0,081	30	1,56
2MP1017M025	1,00 / 1,70	25	0,203	30	2,21
2MP1219M025	1,20 / 1,90	25	0,278	30	2,61
2MP1017M050	1,00 / 1,70	50	0,406	10	3,59
2MP1219M050	1,20 / 1,90	50	0,555	10	4,40
2MP1727M050	1,70 / 2,70	50	1,117	5	5,06
2MP2231M050	2,20 / 3,10	50	1,747	5	6,68
2MP1727M100	1,70 / 2,70	100	2,233	5	9,04
2MP2231M100	2,20 / 3,10	100	3,493	5	12,24





## FILO ZINCATO A ROTOLO [BOBINA]



Articolo	 Ø mm	 ml	 kg pz.	 Pz. conf.	€ cad.
2MZ170M050C	1,70	50	0,890	10	3,84
2MZ220M050C	2,20	50	1,492	10	5,56
2MZ270M050C	2,70	50	2,246	5	7,92
2MZ150M100C	1,50	100	1,387	10	6,75
2MZ170M100C	1,70	100	1,781	10	6,66
2MZ220M100C	2,20	100	2,983	5	10,16
2MZ270M100C	2,70	100	4,492	5	14,75





## FILO ZINCATO A ROTOLO [MATASSA]



Articolo	 Ø mm	 ml	 kg pz.	 Pz. conf.	€ cad.
2MZ100M025	1,00	25	0,1540	30	1,79
2MZ130M025	1,30	25	0,2600	30	2,23
2MZ100M050	1,00	50	0,3080	30	2,74
2MZ130M050	1,30	50	0,5210	10	3,63
2MZ150M050	1,50	50	0,6930	10	4,34
2MZ100M100	1,00	100	0,6160	10	4,74
2MZ130M100	1,30	100	1,0410	10	6,05

## FILO 25 ml [BOBINA]



Articolo	 Ø mm	 ml	 kg pz.	 Pz. conf.	€ cad.
2MZB100M025 zincato	1,00	25	0,154	40	1,94
2MPB1017M025 plastificato	1,00 / 1,70	25	0,203	25	2,34







CHIODI



# CHIODI





## CHIODI TESTA PIANA



Articolo	 Ø mm	N°	 mm	 kg scatola	 kg bancale	€ kg
2CTP1020	1,50	10	20	5,00	-	4,97
2CTP1025	1,50	10	25	5,00	-	4,55
2CTP1030	1,50	10	30	5,00	-	4,27
2CTP1135	1,60	11	35	5,00	-	4,03
2CTP1220	1,80	12	20	5,00	-	3,89
2CTP1330	2,00	13	30	5,00	1080	3,70
2CTP1440	2,20	14	40	5,00	1080	3,23
2CTP1550	2,40	15	50	5,00	1080	3,16
2CTP1660	2,70	16	60	5,00	1080	2,78
2CTP1770	3,00	17	70	5,00	1080	2,78
2CTP1880	3,50	18	80	5,00	1080	2,78
2CTP1990	4,00	19	90	5,00	1080	2,78
2CTP20100	4,50	20	100	5,00	1080	2,78
2CTP21120	5,00	21	120	5,00	1080	2,78
2CTP22140	5,50	22	140	5,00	-	2,98
2CTP23150	6,00	23	150	5,00	-	2,98
2CTP23160	6,00	23	160	5,00	-	2,98
2CTP24180	6,50	24	180	5,00	-	3,03
2CTP24200	6,50	24	200	5,00	-	3,03
2CTP25220	7,00	25	220	5,00	-	3,03
2CTP25250	7,00	25	250	5,00	-	3,03
2CTP27280	8,00	27	280	5,00	-	3,03
2CTP27300	8,00	27	300	5,00	-	3,03





## CHIODI TESTA PIANA 250 gr



Articolo	 Ø mm	N°	 mm	 kg scatola	 Conf. scatola	€ cad.
2CTPGR2501020	1,50	10	20	5,00	20	2,67
2CTPGR2501025	1,50	10	25	5,00	20	2,55
2CTPGR2501030	1,50	10	30	5,00	20	2,47
2CTPGR2501330	2,00	13	30	5,00	20	2,31



## CHIODI TESTA PIANA 500 gr



Articolo	 Ø mm	N°	 mm	 kg scatola	 Conf. scatola	€ cad.
2CTPGR5001440	2,20	14	40	5,00	10	3,27
2CTPGR5001550	2,40	15	50	5,00	10	3,23
2CTPGR5001660	2,70	16	60	5,00	10	3,09
2CTPGR5001770	3,00	17	70	5,00	10	3,02
2CTPGR5001880	3,50	18	80	5,00	10	3,02
2CTPGR50020100	4,50	20	100	5,00	10	2,95

## CHIODI TESTA PIANA LARGA







Articolo	 Ø mm	N°	 mm	 kg scatola	€ kg
2CTPL1012	1,50	10	12	5,00	7,16
2CTPL1116	1,60	11	16	5,00	5,93
2CTPL1218	1,80	12	18	5,00	5,44
2CTPL1220	1,80	12	20	5,00	5,18
2CTPL1225	1,80	12	25	5,00	4,72
2CTPL1335	2,00	13	35	5,00	3,86
2CTPL1525	2,40	15	25	5,00	3,72
2CTPL1725	3,00	17	25	5,00	3,60
2CTPL1730	3,00	17	30	5,00	3,49
2CTPL1735	3,00	17	35	5,00	3,41
2CTPL1840	3,50	18	40	5,00	3,33
2CTPL1845	3,50	18	45	5,00	3,26
2CTPL1850	3,50	18	50	5,00	3,20
2CTPL1860	3,50	18	60	5,00	3,18

Su richiesta e per quantitativi minimi pari a 200 kg si possono produrre diametri e lunghezze diverse

## CHIODI TESTA PIANA LARGA 250 gr





Articolo	 Ø mm	N°	 mm	 kg scatola	 Conf. scatola	€ cad.
2CTPLGR2501116	1,60	11	16	5,00	20	3,11
2CTPLGR2501220	1,80	12	20	5,00	20	2,90
2CTPLGR2501525	2,40	15	25	5,00	20	2,51
2CTPLGR2501730	3,00	17	30	5,00	20	2,44
2CTPLGR2501840	3,50	18	40	5,00	20	2,40

Su richiesta si possono confezionare misure diverse

## CHIODI TESTA PIANA LARGHISSIMA







Articolo	 Ø mm	N°	 mm	 kg scatola	€ kg
2CTPLL1720	3,00	17	20	5,00	4,22
2CTPLL1722	3,00	17	22	5,00	4,05
2CTPLL1725	3,00	17	25	5,00	3,96
2CTPLL1730	3,00	17	30	5,00	3,77
2CTPLL1735	3,00	17	35	5,00	3,63
2CTPLL1840	3,50	18	40	5,00	3,36
2CTPLL1850	3,50	18	50	5,00	3,30
2CTPLL1860	3,50	18	60	5,00	3,27

Su richiesta e per quantitativi minimi pari a 200 kg si possono produrre diametri e lunghezze diverse

## CHIODI TESTA PIANA LARGHISSIMA 250 gr





Articolo	 Ø mm	N°	 mm	 kg scatola	 Conf. scatola	€ cad.
2CTPLLGR2501720	3,00	17	20	5,00	20	2,65
2CTPLLGR2501725	3,00	17	25	5,00	20	2,59
2CTPLLGR2501730	3,00	17	30	5,00	20	2,55
2CTPLLGR2501840	3,50	18	40	5,00	20	2,45

Su richiesta si possono confezionare misure diverse

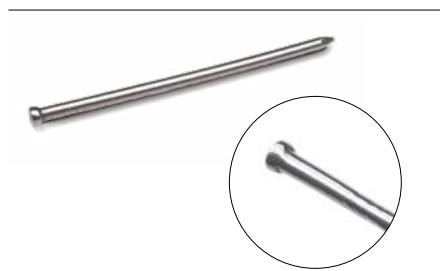
## CHIODI TESTA GRUPPINO







Articolo	 Ø mm	N°	 mm	 kg scatola	€ kg
2CTG0515	1,00	5	15	5,00	11,29
2CTG0620	1,10	6	20	5,00	8,28
2CTG0820	1,30	8	20	5,00	7,07
2CTG0825	1,30	8	25	5,00	6,32
2CTG0830	1,30	8	30	5,00	5,70
2CTG0930	1,40	9	30	5,00	5,21
2CTG1030	1,50	10	30	5,00	4,91
2CTG1035	1,50	10	35	5,00	4,67
2CTG1040	1,50	10	40	5,00	4,63
2CTG1135	1,60	11	35	5,00	4,32
2CTG1240	1,80	12	40	5,00	4,00
2CTG1350	2,00	13	50	5,00	3,81
2CTG1560	2,40	15	60	5,00	3,61
2CTG1670	2,70	16	70	5,00	3,44
2CTG1780	3,00	17	80	5,00	3,32

Su richiesta e per quantitativi minimi pari a 200 kg si possono produrre diametri e lunghezze diverse

## CHIODI TESTA GRUPPINO 250 gr





Articolo	 Ø mm	N°	 mm	 kg scatola	 Conf. scatola	€ cad.
2CTGGR2500515	1,00	5	15	5,00	20	4,47
2CTGGR2500620	1,10	6	20	5,00	20	3,68
2CTGGR2500825	1,30	8	25	5,00	20	3,16
2CTGGR2501030	1,50	10	30	5,00	20	2,79
2CTGGR2501240	1,80	12	40	5,00	20	2,55
2CTGGR2501350	2,00	13	50	5,00	20	2,50

Su richiesta si possono confezionare misure diverse

## CAMBRETTE







Articolo	 Ø mm	N°	 mm	 kg scatola	€ kg
2CC1116	1,60	11	16	5,00	9,22
2CC1218	1,80	12	18	5,00	7,61
2CC1220	1,80	12	20	5,00	6,91
2CC1325	2,00	13	25	5,00	5,51
2CC1430	2,20	14	30	5,00	5,13
2CC1630	2,70	16	30	5,00	4,03
2CC1735	3,00	17	35	5,00	3,83
2CC1840	3,50	18	40	5,00	3,40

Su richiesta e per quantitativi minimi pari a 200 kg si possono produrre diametri e lunghezze diverse

## CAMBRETTE 250 gr



Articolo	 Ø mm	N°	 mm	 kg scatola	 Conf. scatola	€ cad.
2CCGR2501220	1,80	12	20	5,00	20	3,37
2CCGR2501325	2,00	13	25	5,00	20	2,99
2CCGR2501630	2,70	16	30	5,00	20	2,60

Su richiesta si possono confezionare misure diverse

# CHIODI ACCIAIO TEMPRATO

## CHIODI ACCIAIO TESTA BOMBATA



Articolo	Ø mm	N°	mm	kg scatola	Conf. scatola	kg bancale	€ kg
3CATB220	2,00	13	20	2,50	10	-	12,87
3CATB225	2,00	13	25	2,50	10	-	12,87
3CATB330	3,00	17	30	2,50	10	-	11,28
3CATB3540	3,50	18	40	2,50	10	-	8,25
3CATB3750	3,70	19	50	2,50	10	1000	8,25
3CATB3760	3,70	19	60	2,50	10	1000	8,25
3CATB4070	4,00	19	70	2,50	10	-	8,25
3CATB4080	4,00	19	80	2,50	10	-	8,25
3CATB4100	4,00	19	100	2,50	10	-	8,25

Punta: tranciata tonda - Materiali: acciaio C 72 - Durezza: 55-57 HRC - Finitura superficie: blu

## CHIODI ACCIAIO TESTA GRUPPINO



Articolo	Ø mm	N°	mm	kg scatola	Conf. scatola	€ kg
3CATG1216	1,20	7	16	1,00	25	19,06
3CATG1220	1,20	7	20	1,00	25	19,06
3CATG1225	1,20	7	25	1,00	25	19,06
3CATG1230	1,20	7	30	1,00	25	19,06
3CATG1235	1,20	7	35	1,00	25	19,06
3CATG1520	1,50	10	20	1,00	25	18,21
3CATG1525	1,50	10	25	1,00	25	18,21
3CATG1530	1,50	10	30	1,00	25	18,21
3CATG1535	1,50	10	35	1,00	25	18,21
3CATG1540	1,50	10	40	1,00	25	18,21

Punta: tranciata tonda - Materiali: acciaio C 72 - Durezza: 55-57 HRC - Finitura superficie: blu

## CHIODI ACCIAIO ZINCATI TESTA PIANA ZIGRINATA 100 pz



Articolo	Ø mm	N°	mm	Pz. scatola	Conf. scatola	€ cad.
3CATZ40	3,50	18	40	100	50	0,0536
3CATZ50	3,50	18	50	100	50	0,0723
3CATZ60	3,50	18	60	100	50	0,0837
3CATZ70	3,50	18	70	100	50	0,1241

Punta: tranciata balistica - Materiali: acciaio C 72 - Durezza: 55-57 HRC  
Finitura superficie: zincata 5 micron

## CHIODI ACCIAIO ZINCATI TESTA PIANA ZIGRINATA 2,50 kg







Articolo	Ø mm	N°	mm	kg scatola	Conf. scatola	€ kg
3CATZK50	3,50	18	50	2,50	10	10,30
3CATZK60	3,50	18	60	2,50	10	10,30
3CATZK70	3,50	18	70	2,50	10	10,30

Punta: tranciata balistica - Materiali: acciaio C 72 - Durezza: 55-57 HRC  
Finitura superficie: zincata 5 micron

## CHIODI ACCIAIO TEMPRATO TESTA BOMBATA

**I.MA.FER.**







Articolo	 Ø mm	N°	 mm	 kg scatola	 Conf. scatola	 kg bancale	€ kg
4CATB3030	3,00	17	30	2,50	10	900	3,55
4CATB3540	3,50	18	40	2,50	10	900	3,55
4CATB3750	3,70	19	50	2,50	10	900	3,55
4CATB3760	3,70	19	60	2,50	10	900	3,55
4CATB4070	4,00	19	70	2,50	10	900	3,55
4CATB4080	4,00	19	80	2,50	10	900	3,55
4CATB4100	4,00	19	100	2,50	10	900	3,55

## CHIODI FERRO TESTA PIANA

**I.MA.FER.**



Articolo	 Ø mm	N°	 mm	 kg scatola	 kg bancale	€ kg
4CTP1660	2,70	16	60	5,00	1000 - 1080	2,52
4CTP1770	3,00	17	70	5,00	1000 - 1080	2,52
4CTP1880	3,50	18	80	5,00	1000 - 1080	2,52
4CTP20100	4,50	20	100	5,00	1000 - 1080	2,52
4CTP21120	5,00	21	120	5,00	1000 - 1080	2,52
4CTP22140	5,50	22	140	5,00	1000	2,64
4CTP23150	6,00	23	150	5,00	1000	2,64
4CTP23160	6,00	23	160	5,00	1000	2,64
4CTP24180	6,50	24	180	5,00	1000	2,71
4CTP24200	6,50	24	200	5,00	1000	2,71
4CTP25220	7,00	25	220	5,00	1000	2,71
4CTP25250	7,00	25	250	5,00	1000	2,71
4CTP27300	8,00	27	300	5,00	1000	2,71

# RECINZIONI



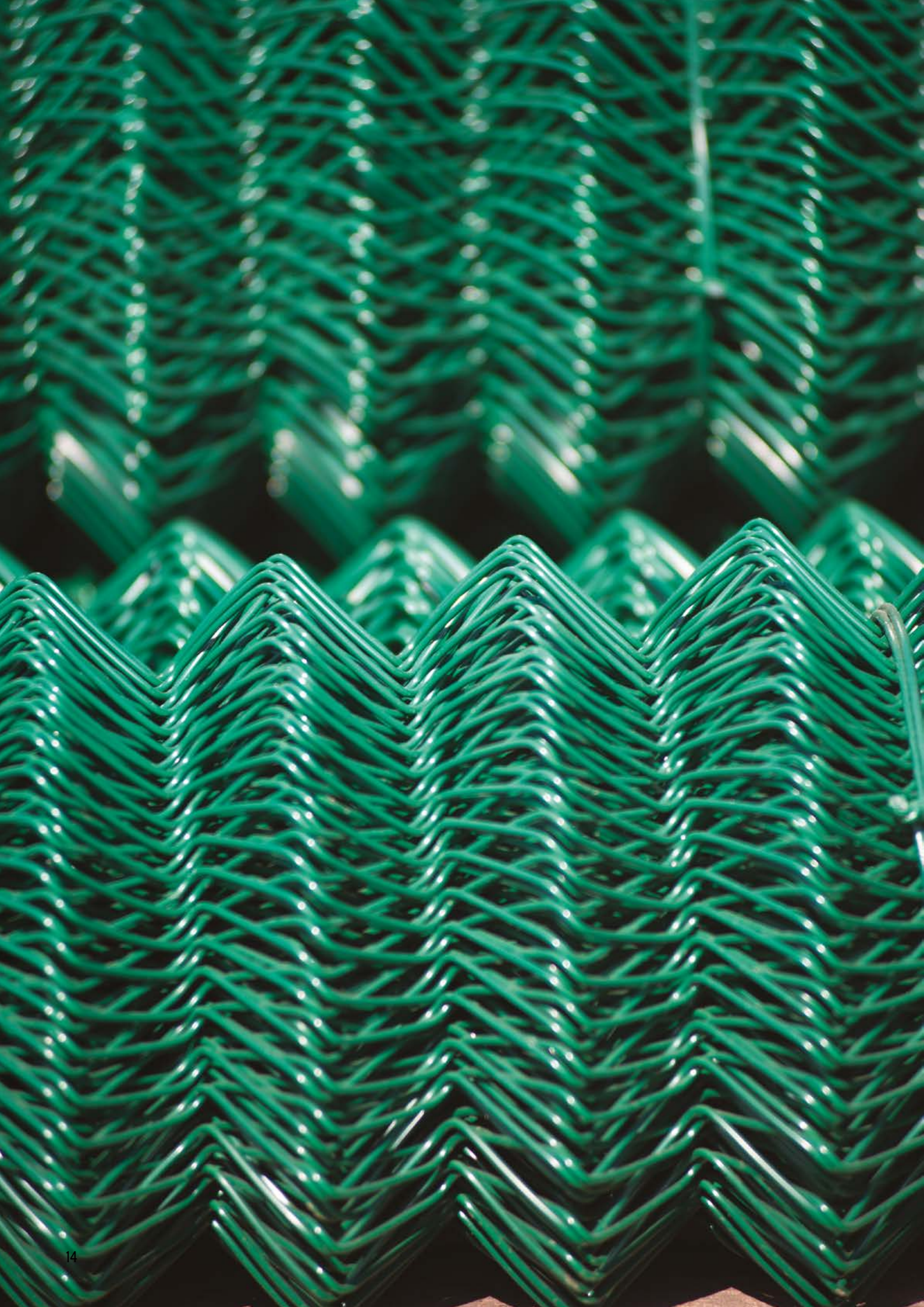





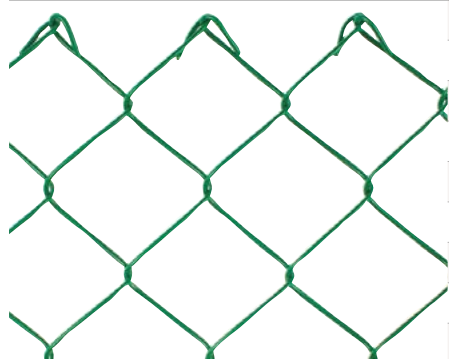

# RECINZIONI

## FREEPLAST LEGGERA



Peso al mq: kg 1,000 ca.





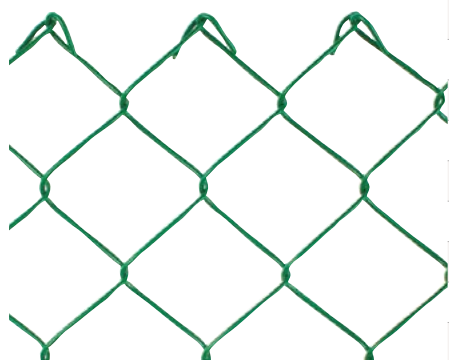

Articolo		 Ø mm	 cm	 ml	 kg rotolo	 rotoli per bancale	€ rotolo
2RP260080	50x50	1,85/2,60	80	25	20,00	12	71,65
2RP260100	50x50	1,85/2,60	100	25	25,00	12	89,09
2RP260125	50x50	1,85/2,60	125	25	31,25	12	110,89
2RP260150	50x50	1,85/2,60	150	25	37,50	12	134,98
2RP260175	50x50	1,85/2,60	175	25	43,75	12	157,12
2RP260200	50x50	1,85/2,60	200	25	50,00	12	179,50
2RP260H080MT10	50x50	1,85/2,60	80	10	8,00	30	31,79
2RP260H100MT10	50x50	1,85/2,60	100	10	10,00	30	39,47
2RP260H125MT10	50x50	1,85/2,60	125	10	12,50	30	49,08
2RP260H150MT10	50x50	1,85/2,60	150	10	15,00	30	59,63
2RP260H175MT10	50x50	1,85/2,60	175	10	17,50	30	69,37
2RP260H200MT10	50x50	1,85/2,60	200	10	20,00	30	79,21

Colore: verde

## FREEPLAST MEDIA



Peso al mq: kg 1,200 ca.





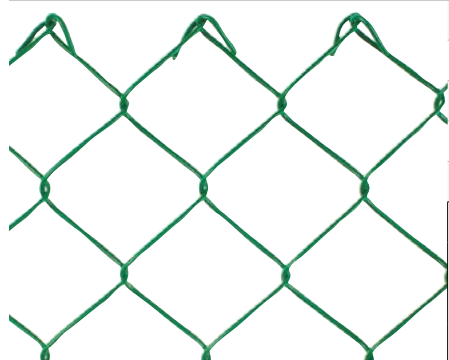

Articolo		 Ø mm	 cm	 ml	 kg rotolo	 rotoli per bancale	€ rotolo
2RP280080	50x50	2,00/2,80	80	25	24,00	12	80,41
2RP280100	50x50	2,00/2,80	100	25	30,00	12	100,04
2RP280125	50x50	2,00/2,80	125	25	37,50	12	124,58
2RP280150	50x50	2,00/2,80	150	25	45,00	12	151,41
2RP280175	50x50	2,00/2,80	175	25	52,50	12	176,28
2RP280200	50x50	2,00/2,80	200	25	60,00	12	201,40
2RP280H080MT10	50x50	2,00/2,80	80	10	9,60	30	35,42
2RP280H100MT10	50x50	2,00/2,80	100	10	12,00	30	44,01
2RP280H125MT10	50x50	2,00/2,80	125	10	15,00	30	54,74
2RP280H150MT10	50x50	2,00/2,80	150	10	18,00	30	66,43
2RP280H175MT10	50x50	2,00/2,80	175	10	21,00	30	77,30
2RP280H200MT10	50x50	2,00/2,80	200	10	24,00	30	88,27

Colore: verde - Colore: antracite - 10 punti dallo sconto base

## FREEPLAST PESANTE







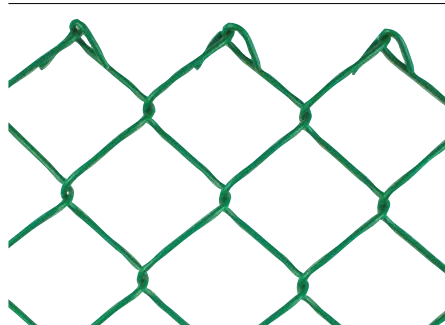

Peso al mq: kg 1,400 ca.

Articolo		 Ø mm	 cm	 ml	 kg rotolo	 rotoli per bancale	€ rotolo
2RP300100	50x50	2,15/3,00	100	25	35,00	12	114,80
2RP300125	50x50	2,15/3,00	125	25	43,75	12	143,03
2RP300150	50x50	2,15/3,00	150	25	52,50	12	173,55
2RP300175	50x50	2,15/3,00	175	25	61,25	12	202,12
2RP300200	50x50	2,15/3,00	200	25	70,00	12	230,92

Colore: verde

## FREEPLAST SUPER 48x48







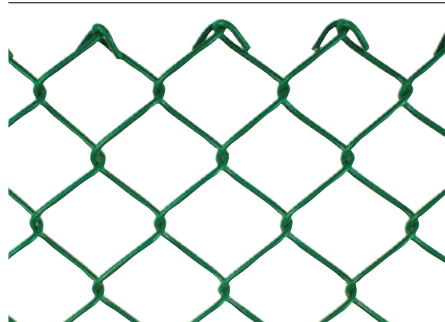

Articolo	 48x48	 Ø mm	 cm	 ml	 kg mq	 rotoli per bancale	€ kg
<b>2RPK3004848</b>	48x48	2,20/3,00	50-300	12,5	1,55	12	<b>4,46</b>
<b>2RPK3204848</b>	48x48	2,40/3,20	50-300	12,5	1,90	12	<b>4,32</b>
<b>2RPK3404848</b>	48x48	2,70/3,40	50-300	12,5	2,40	12	<b>4,14</b>
<b>2RPK4004848</b>	48x48	3,00/4,00	50-300	12,5	3,00	12	<b>4,06</b>

Colore: verde - Colore: antracite/bianco/marrone - 10 punti dallo sconto base

## FREEPLAST SUPER 30x30







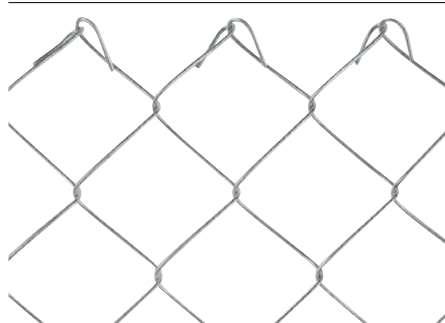

Articolo	 30x30	 Ø mm	 cm	 ml	 kg mq	 rotoli per bancale	€ kg
<b>2RP3030</b>	30x30	2,00/2,80	50-200	12,5	2,20	12	<b>4,64</b>

Colore: verde

Su richiesta per rot 40 si produce fino a cm 300

## FREENET 13







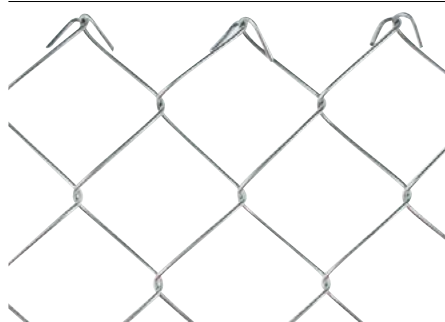

Articolo	 50x50	 Ø mm	 cm	 ml	 kg rotolo	 rotoli per bancale	€ rotolo
<b>2RZ13100</b>	50x50	2,00	100	25	24,00	12	<b>78,12</b>
<b>2RZ13125</b>	50x50	2,00	125	25	30,00	12	<b>97,33</b>
<b>2RZ13150</b>	50x50	2,00	150	25	36,00	12	<b>117,20</b>
<b>2RZ13175</b>	50x50	2,00	175	25	42,00	12	<b>136,60</b>
<b>2RZ13200</b>	50x50	2,00	200	25	48,00	12	<b>156,11</b>

Finitura: zincata a caldo

Peso al mq: kg 0,960 ca.

## FREENET 14







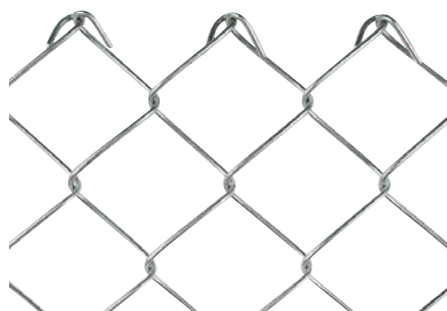

Articolo	 50x50	 Ø mm	 cm	 ml	 kg rotolo	 rotoli per bancale	€ rotolo
<b>2RZ14100</b>	50x50	2,15	100	25	30,00	12	<b>93,78</b>
<b>2RZ14125</b>	50x50	2,15	125	25	37,50	12	<b>116,90</b>
<b>2RZ14150</b>	50x50	2,15	150	25	45,00	12	<b>140,69</b>
<b>2RZ14175</b>	50x50	2,15	175	25	52,50	12	<b>164,00</b>
<b>2RZ14200</b>	50x50	2,15	200	25	60,00	12	<b>187,43</b>

Finitura: zincata a caldo

Peso al mq: kg 1,200 ca.

## FREENET SUPER 48x48







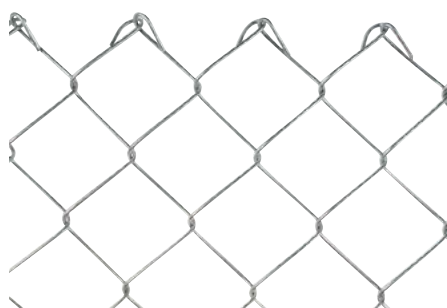

Articolo							€ kg
	Ø mm	cm	ml	kg mq	rotoli per bancale		
<b>2RZK144848</b>	48x48	2,20	50-300	12,5	1,35	12	<b>3,53</b>
<b>2RZK154848</b>	48x48	2,40	50-300	12,5	1,65	12	<b>3,36</b>
<b>2RZK164848</b>	48x48	2,70	50-300	12,5	2,10	12	<b>3,20</b>
<b>2RZK174848</b>	48x48	3,00	50-300	12,5	2,70	12	<b>3,07</b>

Finitura: zincata a caldo

## FREENET SUPER 30x30







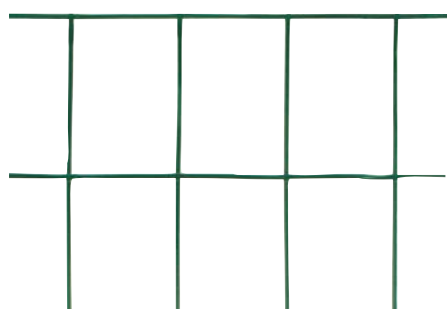

Articolo							€ kg
	Ø mm	cm	ml	kg mq	rotoli per bancale		
<b>2RZK143030</b>	30x30	2,20	50-200	12,50	2,15	12	<b>3,55</b>
<b>2RZK173030</b>	30x30	3,00	50-200	12,50	4,20	12	<b>3,08</b>

Finitura: zincata a caldo

Su richiesta per rot 40 si produce fino a cm 300







## HOBBYPLAST 50x75

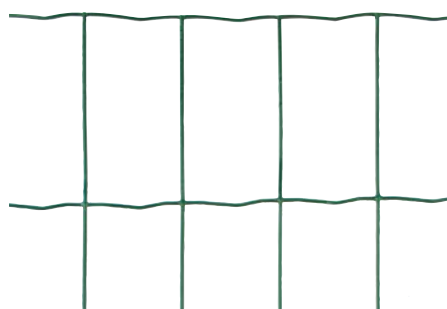

Articolo							€ rotolo
	Ø mm	cm	ml	kg rotolo	rotoli per bancale		
<b>3EP5075080</b>	50x75	2,40	80	25	16,20	12	<b>86,34</b>
<b>3EP5075100</b>	50x75	2,40	100	25	19,40	12	<b>104,76</b>
<b>3EP5075120</b>	50x75	2,40	125	25	24,40	12	<b>130,94</b>
<b>3EP5075150</b>	50x75	2,40	150	25	29,60	12	<b>157,14</b>
<b>3EP5075180</b>	50x75	2,40	175	25	34,40	12	<b>183,32</b>
<b>3EP5075200</b>	50x75	2,40	200	25	39,80	12	<b>209,52</b>

## EUROPLAST 50x100







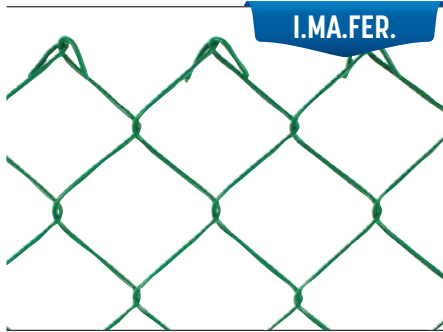

Articolo							€ rotolo
	Ø mm	cm	ml	kg rotolo	rotoli per bancale		
<b>3EPL50100060</b>	50x100	2,20	60	25	7,80	20	<b>48,05</b>
<b>3EPL50100080</b>	50x100	2,20	80	25	10,60	20	<b>62,84</b>
<b>3EPL50100100</b>	50x100	2,20	100	25	13,20	16	<b>76,24</b>
<b>3EPL50100120</b>	50x100	2,20	120	25	15,80	16	<b>91,49</b>
<b>3EPL50100150</b>	50x100	2,20	150	25	19,40	16	<b>114,36</b>
<b>3EPL50100180</b>	50x100	2,20	180	25	23,20	16	<b>137,22</b>
<b>3EPL50100200</b>	50x100	2,20	200	25	25,60	16	<b>152,47</b>

# RECINZIONI

## RETE PLASTICATA MAGLIA SCIOLTA



**I.MA.FER.**





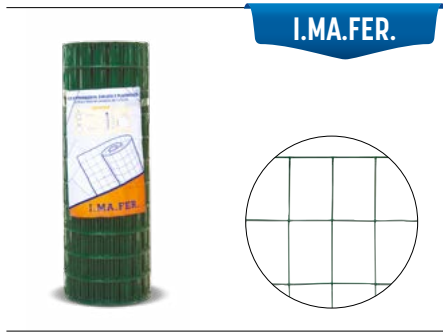

Articolo		 Ø mm	 cm	 ml	 kg rotolo	 rotoli per bancale	€ rotolo
<b>4RP250100</b>	50x50	1,60-2,50	100	25	20,00	20	<b>71,91</b>
<b>4RP250125</b>	50x50	1,60-2,50	125	25	25,00	20	<b>89,89</b>
<b>4RP250150</b>	50x50	1,60-2,50	150	25	30,00	20	<b>107,87</b>
<b>4RP250175</b>	50x50	1,60-2,50	175	25	35,00	20	<b>125,85</b>
<b>4RP250200</b>	50x50	1,60-2,50	200	25	40,00	20	<b>143,82</b>

Peso al mq: kg 0,800 ca.

## RETE ELETTROSALDATA ZINCATA E PLASTIFICATA







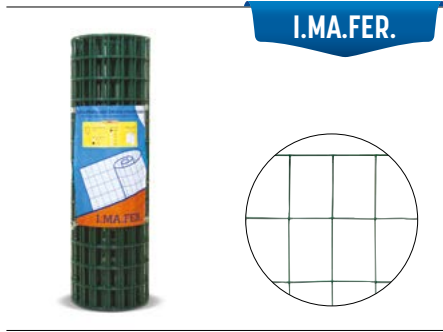

**I.MA.FER.**

Articolo		 Ø mm	 cm	 ml	 kg rotolo	 rotoli per bancale	€ rotolo
<b>4EP5075100</b>	50x75	1,80-2,40	100	25	18,50	12	<b>84,94</b>
<b>4EP5075125</b>	50x75	1,80-2,40	125	25	21,00	12	<b>106,18</b>
<b>4EP5075150</b>	50x75	1,80-2,40	150	25	27,30	12	<b>127,41</b>
<b>4EP5075175</b>	50x75	1,80-2,40	175	25	32,20	12	<b>148,65</b>
<b>4EP5075200</b>	50x75	1,80-2,40	200	25	36,30	12	<b>169,88</b>

## RETE ELETTROSALDATA ZINCATA E PLASTIFICATA



**I.MA.FER.**







Articolo		 Ø mm	 cm	 ml	 kg rotolo	 rotoli per bancale	€ rotolo
<b>4EPL5075100</b>	50x75	1,70-2,10	100	25	15,50	16	<b>64,86</b>
<b>4EPL5075125</b>	50x75	1,70-2,10	125	25	18,60	16	<b>81,08</b>
<b>4EPL5075150</b>	50x75	1,70-2,10	150	25	23,50	16	<b>97,29</b>
<b>4EPL5075175</b>	50x75	1,70-2,10	175	25	26,50	16	<b>113,51</b>
<b>4EPL5075200</b>	50x75	1,70-2,10	200	25	29,50	16	<b>129,52</b>
<b>4EPL5075H100MT10</b>	50x75	1,70-2,10	100	10	6,10	-	<b>31,24</b>
<b>4EPL5075H125MT10</b>	50x75	1,70-2,10	125	10	7,40	-	<b>39,05</b>
<b>4EPL5075H150MT10</b>	50x75	1,70-2,10	150	10	9,25	-	<b>46,86</b>
<b>4EPL5075H175MT10</b>	50x75	1,70-2,10	175	10	10,80	-	<b>54,67</b>
<b>4EPL5075H200MT10</b>	50x75	1,70-2,10	200	10	12,35	-	<b>62,48</b>

# RECINZIONI

## RETE ELETTROSALDATA ZINCATA E PLASTIFICATA







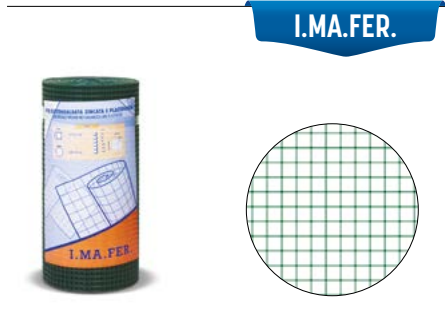

**I.MA.FER.**

Articolo		 Ø mm	 cm	 ml	 kg rotolo	 rotoli per bancale	€ rotolo
<b>4EP6075100</b>	60x75	1,70-2,20	100	25	14,50	16	<b>59,07</b>
<b>4EP6075125</b>	60x75	1,70-2,20	125	25	17,00	16	<b>66,79</b>
<b>4EP6075150</b>	60x75	1,70-2,20	150	25	21,50	16	<b>80,15</b>
<b>4EP6075175</b>	60x75	1,70-2,20	175	25	24,00	16	<b>100,00</b>
<b>4EP6075200</b>	60x75	1,70-2,20	200	25	28,50	16	<b>110,42</b>

## RETE ELETTROSALDATA ZINCATA E PLASTIFICATA







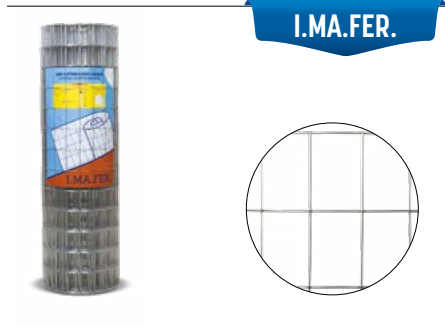

**I.MA.FER.**

Articolo		 Ø mm	 cm	 ml	 kg rotolo	 rotoli per bancale	€ rotolo
<b>4EP1313050</b>	13x13	0,80-1,20	50	25	10,00	20	<b>36,06</b>
<b>4EP1313060</b>	13x13	0,80-1,20	60	25	12,50	20	<b>41,50</b>
<b>4EP1313080</b>	13x13	0,80-1,20	80	25	15,50	20	<b>54,73</b>
<b>4EP1313100</b>	13x13	0,80-1,20	100	25	21,00	20	<b>62,76</b>
<b>4EP1313120</b>	13x13	0,80-1,20	120	25	24,50	20	<b>74,83</b>
<b>4EP1313150</b>	13x13	0,80-1,20	150	25	30,00	20	<b>97,47</b>

## RETE ELETTROSALDATA ZINCATA PRIMA







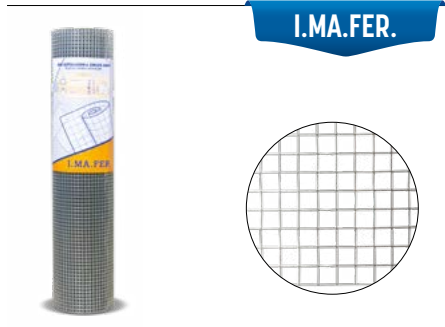

**I.MA.FER.**

Articolo		 Ø mm	 cm	 ml	 kg rotolo	 rotoli per bancale	€ rotolo
<b>4EZ5075100</b>	50x75	1,60	100	25	13,50	16	<b>50,40</b>
<b>4EZ5075125</b>	50x75	1,60	125	25	16,50	16	<b>63,00</b>
<b>4EZ5075150</b>	50x75	1,60	150	25	20,00	16	<b>75,60</b>
<b>4EZ5075175</b>	50x75	1,60	175	25	23,00	16	<b>88,20</b>
<b>4EZ5075200</b>	50x75	1,60	200	25	26,50	16	<b>100,80</b>

## RETE ELETTROSALDATA ZINCATA DOPO







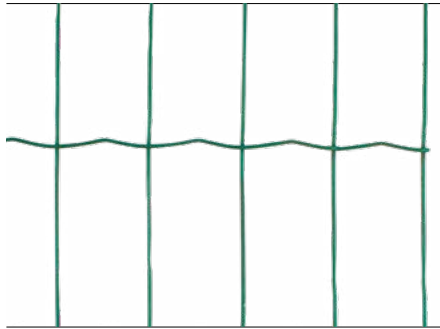

**I.MA.FER.**

Articolo		 Ø mm	 cm	 ml	 kg rotolo	 rotoli per bancale	€ rotolo
<b>4EZD1313050</b>	13x13	1,00	50	25	10	20	<b>52,88</b>
<b>4EZD1313060</b>	13x13	1,00	60	25	12	20	<b>59,85</b>
<b>4EZD1313080</b>	13x13	1,00	80	25	15,5	20	<b>81,30</b>
<b>4EZD1313100</b>	13x13	1,00	100	25	20,5	20	<b>96,80</b>
<b>4EZD1313125</b>	13x13	1,00	125	25	26,5	20	<b>120,54</b>
<b>4EZD1313150</b>	13x13	1,00	150	25	31	20	<b>146,70</b>

# RECINZIONI







## HORTAPLAST 50x100

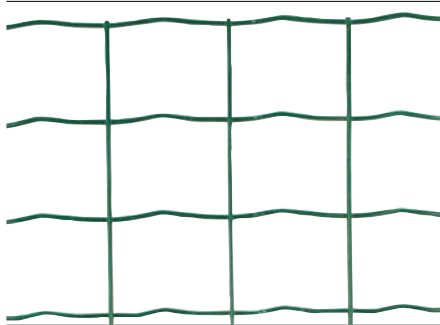

Articolo		 Ø mm	 cm	 ml	 kg rotolo	 rotoli per bancale	€ rotolo
3EP50100060	50x100	2,50	60	25	12,80	12	<b>71,44</b>
3EP50100080	50x100	2,50	80	25	16,80	12	<b>91,13</b>
3EP50100100	50x100	2,50	100	25	20,40	12	<b>109,30</b>
3EP50100120	50x100	2,50	120	25	24,20	12	<b>129,28</b>
3EP50100150	50x100	2,50	150	25	29,50	12	<b>159,23</b>
3EP50100180	50x100	2,50	180	25	34,60	12	<b>189,18</b>
3EP50100200	50x100	2,50	200	25	38,00	12	<b>209,14</b>







## MULTIPLAST 50x60

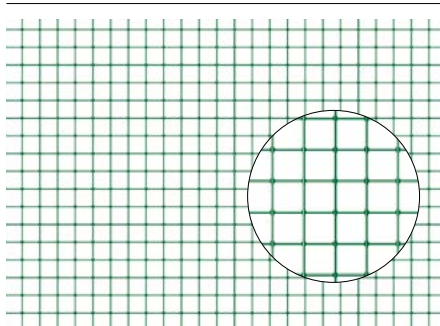

Articolo		 Ø mm	 cm	 ml	 kg rotolo	 rotoli per bancale	€ rotolo
3EP5060100	50x60	3,00	100	25	38,00	9	<b>205,79</b>
3EP5060120	50x60	3,00	120	25	45,60	9	<b>246,95</b>
3EP5060150	50x60	3,00	150	25	67,00	9	<b>308,67</b>
3EP5060180	50x60	3,00	180	25	68,40	9	<b>370,42</b>
3EP5060200	50x60	3,00	200	25	76,00	9	<b>411,58</b>
3EP5060220	50x60	3,00	220	25	83,60	9	<b>475,37</b>
3EP5060250	50x60	3,00	250	25	95,00	9	<b>540,18</b>







## VOLIPLAST 13x13

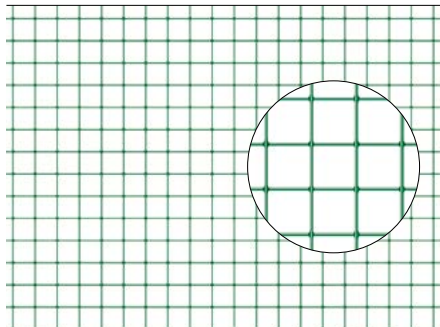

Articolo		 Ø mm	 cm	 ml	 kg rotolo	 rotoli per bancale	€ rotolo
3EP1313050	13x13	1,20	50	25	9,40	20	<b>64,48</b>
3EP1313060	13x13	1,20	60	25	11,30	20	<b>76,63</b>
3EP1313080	13x13	1,20	80	25	15,00	20	<b>101,20</b>
3EP1313100	13x13	1,20	100	25	18,80	20	<b>124,01</b>
3EP1313120	13x13	1,20	120	25	22,50	20	<b>148,81</b>
3EP1313150	13x13	1,20	150	25	28,10	20	<b>186,00</b>
3EP1313200	13x13	1,20	200	25	37,50	20	<b>273,43</b>







## VOLIPLAST 16x16

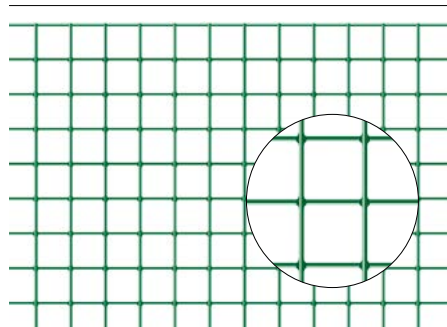

Articolo		 Ø mm	 cm	 ml	 kg rotolo	 rotoli per bancale	€ rotolo
3EP1616050	16x16	1,20	50	25	7,80	20	<b>55,72</b>
3EP1616060	16x16	1,20	60	25	9,30	20	<b>66,24</b>
3EP1616100	16x16	1,20	100	25	15,50	20	<b>107,16</b>
3EP1616120	16x16	1,20	120	25	18,60	20	<b>128,60</b>
3EP1616150	16x16	1,20	150	25	23,30	20	<b>160,76</b>







## VOLIPLAST 25x25

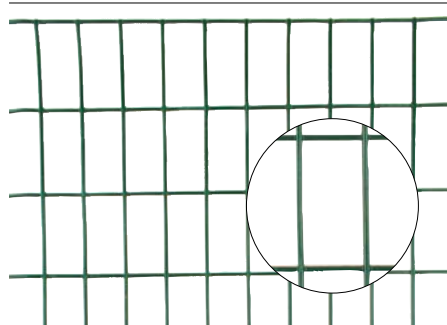

Articolo		 Ø mm	 cm	 ml	 kg rotolo	 rotoli per bancale	€ rotolo
<b>3EP2525100</b>	25x25	2,30	100	25	40,00	9	<b>233,03</b>
<b>3EP2525150</b>	25x25	2,30	150	25	60,00	9	<b>349,55</b>







## VOLIPLAST 50x25

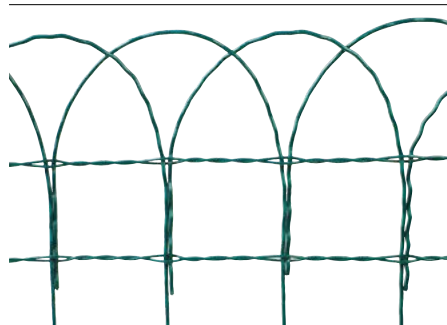

Articolo		 Ø mm	 cm	 ml	 kg rotolo	 rotoli per bancale	€ rotolo
<b>3EP5025100</b>	50x25	2,60	100	25	38,50	9	<b>233,61</b>
<b>3EP5025120</b>	50x25	2,60	120	25	46,50	9	<b>280,33</b>
<b>3EP5025150</b>	50x25	2,60	150	25	58,00	9	<b>350,41</b>
<b>3EP5025180</b>	50x25	2,60	180	25	69,50	9	<b>420,49</b>
<b>3EP5025200</b>	50x25	2,60	200	25	77,00	9	<b>467,21</b>

## BORDERPLAST 85x150









Articolo		 Ø mm	 cm	 ml	 kg rotolo	 rotoli per bancale	€ rotolo
<b>3ROP040</b>	85x150	2,10/3,10	40	25	9,00	18	<b>71,38</b>
<b>3ROP065</b>	85x150	2,10/3,10	65	25	14,00	18	<b>85,75</b>
<b>3ROP090</b>	85x150	2,10/3,10	90	25	19,00	9	<b>114,75</b>
<b>3ROPH04010</b>	85x150	2,10/3,10	40	10	3,60	-	<b>31,80</b>
<b>3ROPH06510</b>	85x150	2,10/3,10	65	10	5,60	-	<b>41,40</b>

Ø filo orizzontale: 1,50/2,10 mm - Ø filo verticale: 2,10/3,10 mm

## MULTINET 50x75







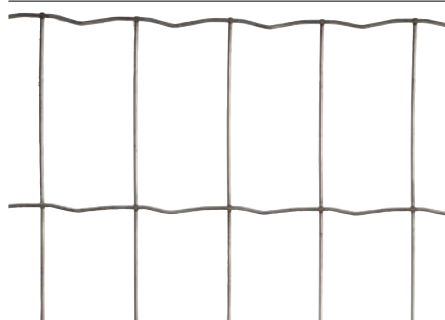

Articolo		 Ø mm	 cm	 ml	 kg rotolo	 rotoli per bancale	€ rotolo
<b>3EZ5075080</b>	50x75	1,90	80	25	15,00	12	<b>31,25</b>
<b>3EZ5075100</b>	50x75	1,90	100	25	19,00	12	<b>75,82</b>
<b>3EZ5075120</b>	50x75	1,90	125	25	23,50	12	<b>94,76</b>
<b>3EZ5075150</b>	50x75	1,90	150	25	28,00	12	<b>113,72</b>
<b>3EZ5075180</b>	50x75	1,90	175	25	32,50	12	<b>132,67</b>
<b>3EZ5075200</b>	50x75	1,90	200	25	37,50	12	<b>151,63</b>

Zincata prima della saldatura - Certificata anticaduta

## MULTIFORT 50x100







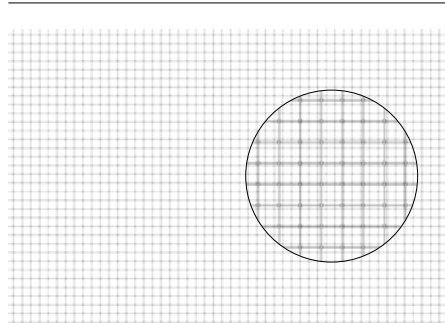

Articolo		 Ø mm	 cm	 ml	 kg rotolo	 rotoli per bancale	€ rotolo
<b>3EZ50100100</b>	50x100	2,60	100	25	32,00	9	<b>149,37</b>
<b>3EZ50100120</b>	50x100	2,60	120	25	38,00	9	<b>179,26</b>
<b>3EZ50100150</b>	50x100	2,60	150	25	48,00	9	<b>224,06</b>
<b>3EZ50100180</b>	50x100	2,60	180	25	57,50	9	<b>268,89</b>
<b>3EZ50100200</b>	50x100	2,60	200	25	64,00	9	<b>298,75</b>

Zincata prima della saldatura







## VOLIFORT 6x6 ZINCATA DOPO

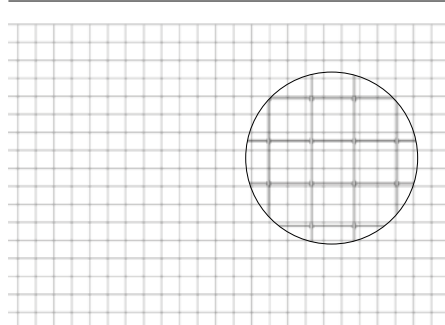

Articolo		 Ø mm	 cm	 ml	 kg rotolo	 rotoli per bancale	€ rotolo
<b>3EZD66050</b>	6x6	0,65	50	25	11,80	20	<b>133,49</b>
<b>3EZD66100</b>	6x6	0,65	100	25	23,50	20	<b>256,71</b>







## VOLIFORT 13x13 ZINCATA DOPO

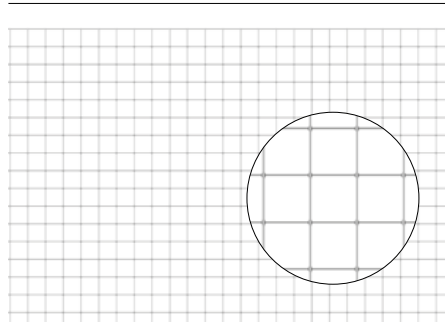

Articolo		 Ø mm	 cm	 ml	 kg rotolo	 rotoli per bancale	€ rotolo
<b>3EZD1313050</b>	13x13	0,90	50	25	9,60	20	<b>83,06</b>
<b>3EZD1313060</b>	13x13	0,90	60	25	11,60	20	<b>98,71</b>
<b>3EZD1313080</b>	13x13	0,90	80	25	15,40	20	<b>130,33</b>
<b>3EZD1313100</b>	13x13	0,90	100	25	19,30	20	<b>159,73</b>
<b>3EZD1313120</b>	13x13	0,90	120	25	23,10	20	<b>191,67</b>
<b>3EZD1313150</b>	13x13	0,90	150	25	28,90	20	<b>239,59</b>







## VOLIFORT 16x16 ZINCATA DOPO

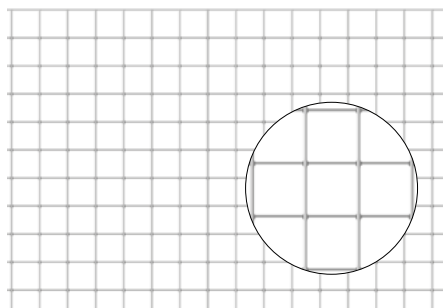

Articolo		 Ø mm	 cm	 ml	 kg rotolo	 rotoli per bancale	€ rotolo
<b>3EZD1616100</b>	16x16	0,90	100	25	16,00	20	<b>145,61</b>
<b>3EZD1616150</b>	16x16	0,90	150	25	24,00	20	<b>218,41</b>







## VOLIFORT 19x19 ZINCATA DOPO

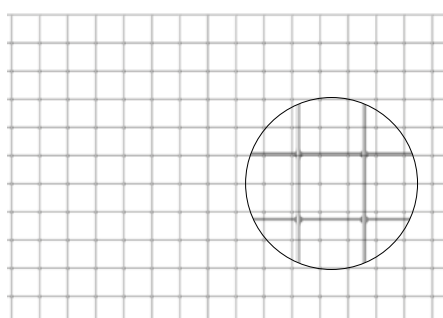

Articolo		 Ø mm	 cm	 ml	 kg rotolo	 rotoli per bancale	€ rotolo
<b>3EZD1919100</b>	19x19	1,45	100	25	36,80	14	<b>258,63</b>
<b>3EZD1919150</b>	19x19	1,45	150	25	55,10	14	<b>387,93</b>





## VOLIFORT 25x25 ZINCATA DOPO



Articolo		 Ø mm	 cm	 ml	 kg rotolo	 rotoli per bancale	€ rotolo
<b>3EZD2525100</b>	25x25	1,75	100	25	39,00	12	<b>261,26</b>
<b>3EZD2525120</b>	25x25	1,75	120	25	46,80	12	<b>313,51</b>





## FLYNET 13x13 ZINCATA PRIMA

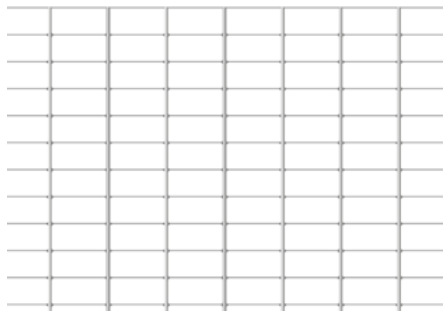

Articolo		 Ø mm	 cm	 ml	 kg rotolo	€ rotolo
<b>3EZP1212H050</b>	13x13	1,40	50	25	23,50	<b>109,03</b>
<b>3EZP1212H060</b>	13x13	1,40	60	25	28,00	<b>130,83</b>
<b>3EZP1212H080</b>	13x13	1,40	80	25	37,50	<b>174,45</b>
<b>3EZP1212H100</b>	13x13	1,40	100	25	46,50	<b>218,05</b>
<b>3EZP1212H150</b>	13x13	1,40	150	25	70,00	<b>327,08</b>

## FLYNET 13x25 ZINCATA PRIMA





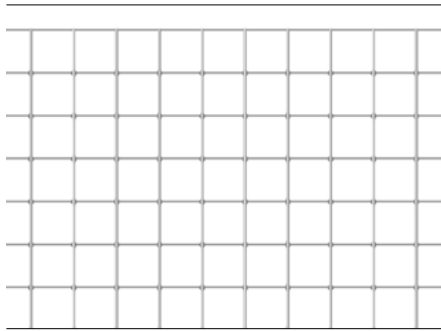

Articolo		 Ø mm	 cm	 ml	 kg rotolo	€ rotolo
<b>3EZP1225H050</b>	13x25	1,40	50	25	17,50	<b>81,38</b>
<b>3EZP1225H060</b>	13x25	1,40	60	25	21,00	<b>97,65</b>
<b>3EZP1225H080</b>	13x25	1,40	80	25	28,00	<b>130,21</b>
<b>3EZP1225H100</b>	13x25	1,40	100	25	35,00	<b>162,77</b>
<b>3EZP1225H150</b>	13x25	1,40	150	25	52,50	<b>244,13</b>

# RECINZIONI





## FLYNET 19x19 ZINCATA PRIMA

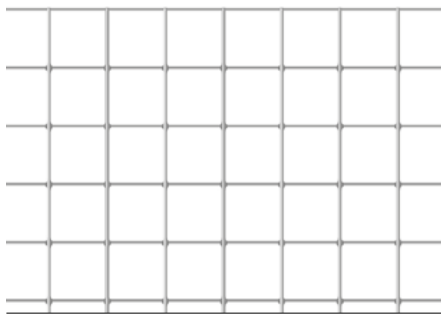

Articolo		 Ø mm	 cm	 ml	 kg rotolo	€ rotolo
<b>3EZP1919H050</b>	19x19	1,40	50	25	15,50	<b>73,16</b>
<b>3EZP1919H060</b>	19x19	1,40	60	25	19,00	<b>87,80</b>
<b>3EZP1919H080</b>	19x19	1,40	80	25	25,00	<b>117,06</b>
<b>3EZP1919H100</b>	19x19	1,40	100	25	31,00	<b>146,32</b>
<b>3EZP1919H150</b>	19x19	1,40	150	25	46,50	<b>219,50</b>





## FLYNET 25x25 ZINCATA PRIMA

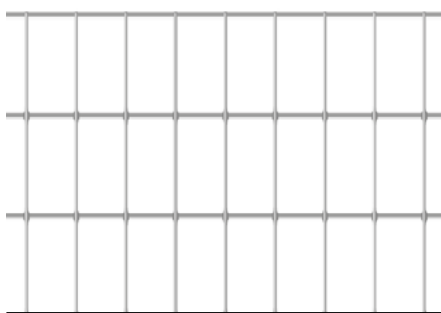

Articolo		 Ø mm	 cm	 ml	 kg rotolo	€ rotolo
<b>3EZP2525H100</b>	25x25	1,60	100	25	30	<b>151,55</b>





## FLYNET 50x25 ZINCATA PRIMA

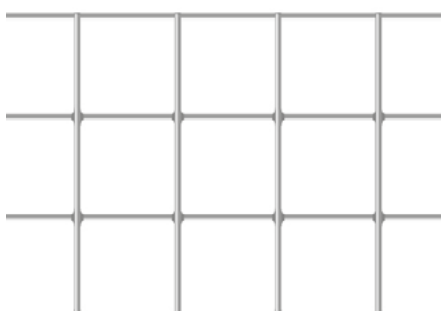

Articolo		 Ø mm	 cm	 ml	 kg rotolo	€ rotolo
<b>3EZP2550H100</b>	50x25	1,90	100	25	33,00	<b>158,50</b>
<b>3EZP2550H120</b>	50x25	1,90	120	25	39,50	<b>190,22</b>
<b>3EZP2550H150</b>	50x25	1,90	150	25	49,50	<b>237,76</b>
<b>3EZP2550H200</b>	50x25	1,90	200	25	65,50	<b>317,03</b>







## FLYNET 50x50 ZINCATA PRIMA

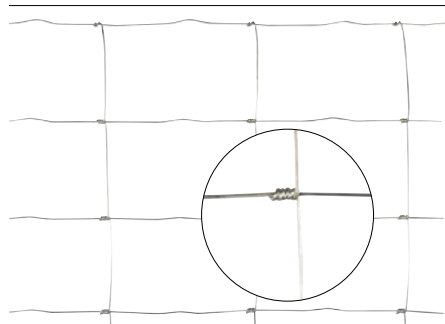

Articolo		 Ø mm	 cm	 ml	 kg rotolo	€ rotolo
<b>3EZP5050H100</b>	50x50	1,90	100	25	22,00	<b>103,34</b>
<b>3EZP5050H120</b>	50x50	1,90	120	25	26,50	<b>124,00</b>
<b>3EZP5050H150</b>	50x50	1,90	150	25	33,00	<b>155,00</b>
<b>3EZP5050H180</b>	50x50	1,90	180	25	39,50	<b>185,99</b>
<b>3EZP5050H200</b>	50x50	1,90	200	25	44,00	<b>206,67</b>

## AGRINET 150







Articolo		 Ø mm	 cm	 ml	 kg rotolo	 rotoli per bancale	€ rotolo
<b>3PAS100</b>	150	1,90/2,20	100	50	18,40	20	<b>72,95</b>
<b>3PAS120</b>	150	1,90/2,20	120	50	22,10	20	<b>87,91</b>
<b>3PAS140</b>	150	1,90/2,20	140	50	29,40	20	<b>108,34</b>
<b>3PAS150</b>	150	1,90/2,50	145	50	36,80	14	<b>141,71</b>
<b>3PAS200</b>	150	1,90/2,50	200	50	44,10	14	<b>172,33</b>

cm				
20,32				
20,32	cm			
15,24	15,24			
15,24	10,16			
10,16	10,16			
10,16	10,16			
10,16	10,16			
10,16	10,16	cm		
10,16	10,16	20,32		
10,16	10,16	20,32		
10,16	10,16	15,24	cm	
10,16	10,16	15,24	20,32	cm
10,16	10,16	10,16	20,32	20,32
10,16	5,08	10,16	20,32	20,32
5,08	5,08	10,16	15,24	15,24
5,08	5,08	10,16	15,24	15,24
5,08	5,08	10,16	10,16	10,16
5,08	5,08	10,16	10,16	10,16
5,08	5,08	10,16	10,16	10,16
5,08	5,08	10,16	10,16	10,16
200/20/15	150/18/15	140/12/15	120/9/15	100/8/15

## PALI PLASTICATI LEGGERI VERDI



Articolo	 Sezione	 cm	 kg pz.	 Pz. fascio	€ cad.
<b>3PLP100</b>	30x30x3,50	100	1,45	10	<b>5,70</b>
<b>3PLP125</b>	30x30x3,50	125	1,80	10	<b>7,22</b>
<b>3PLP150</b>	30x30x3,50	150	2,20	10	<b>8,65</b>
<b>3PLP175</b>	30x30x3,50	175	2,55	10	<b>10,08</b>
<b>3PLP200</b>	35x35x4,00	200	3,60	5	<b>14,89</b>
<b>3PLP225</b>	35x35x4,00	225	4,10	5	<b>16,80</b>
<b>3PLP250</b>	35x35x4,00	250	4,50	5	<b>18,66</b>
<b>3PLP300</b>	35x35x4,00	300	5,50	5	<b>22,40</b>

Piastra a 2 fori 60x140 mm saldata al piede del palo + € 14,00 netto

Piastra a 4 fori 80x140 mm saldata al piede del palo + € 16,00 netto

\* Idonea per rete H max 150

## PALI PLASTICATI LEGGERI ANTRACITE



Articolo	T Sezione	↑ cm	⚖ kg pz.	≡ Pz. fascio	€ cad.
<b>3PLPA125</b>	30x30x3,50	120	1,80	10	<b>7,93</b>
<b>3PLPA150</b>	30x30x3,50	150	2,20	10	<b>9,52</b>
<b>3PLPA175</b>	30x30x3,50	175	2,55	10	<b>11,08</b>
<b>3PLPA200</b>	35x35x4,00	200	3,60	5	<b>16,41</b>
<b>3PLPA225</b>	35x35x4,00	225	4,10	5	<b>18,48</b>
<b>3PLPA250</b>	35x35x4,00	250	4,50	5	<b>20,52</b>
Piastra a 2 fori 60x140 mm saldata al piede del palo					+ € 14,00 netto
Piastra a 4 fori 80x140 mm saldata al piede del palo					+ € 16,00 netto

\* Idonea per rete H max 150

## PALI PLASTICATI PESANTI



Articolo	T Sezione	↑ cm	⚖ kg pz.	≡ Pz. fascio	€ cad.
<b>3PPN130</b>	30x30x5,00	130	2,66	10	<b>10,90</b>
<b>3PPN160</b>	30x30x5,00	160	3,35	10	<b>13,79</b>
<b>3PPN182</b>	30x30x5,00	182	3,80	10	<b>15,59</b>
<b>3PPN206</b>	35x35x5,50	206	5,80	5	<b>23,80</b>
<b>3PPN235</b>	35x35x5,50	235	6,50	5	<b>26,67</b>
<b>3PPN255</b>	35x35x5,50	255	7,10	5	<b>29,21</b>
<b>3PPN295</b>	40x40x4,50	300	7,60	5	<b>31,03</b>

## SAETTE PLASTICATE VERDI



Articolo	Per pali h	L Sezione	↑ cm	⚖ kg pz.	≡ Pz. fascio	€ cad.
<b>3SP120</b>	100-125-150	25x25	120	1,20	10	<b>6,15</b>
<b>3SP150</b>	175	25x25	150	1,50	10	<b>7,66</b>
<b>3SP200</b>	200-225-250	25x25	200	2,00	10	<b>10,29</b>



Articolo	Per pali h	T Sezione	↑ cm	⚖ kg pz.	≡ Pz. fascio	€ cad.
<b>3SPT200</b>	200-225-250	30x3,5	200	2,64	10	<b>18,00</b>
<b>3SPT225</b>	225-250-300	30x3,5	225	3,52	10	<b>20,30</b>

## SAETTE PLASTICATE ANTRACITE

Articolo	Per pali h	L Sezione	↑ cm	kg pz.	Pz. fascio	€ cad.
<b>3SPA120</b>	100-125-150	25x25	120	1,20	10	<b>6,77</b>
<b>3SPA150</b>	175	25x25	150	1,50	10	<b>8,44</b>
<b>3SPA200</b>	200-225-250	25x25	200	2,00	10	<b>11,30</b>



## PALI ZINCATI LEGGERI

Articolo	T Sezione	↑ cm	kg pz.	Pz. fascio	€ cad.
<b>3PLZ100</b>	30x30x3,50	100	1,45	10	<b>7,52</b>
<b>3PLZ125</b>	30x30x3,50	125	1,80	10	<b>10,30</b>
<b>3PLZ150</b>	30x30x3,50	150	2,20	10	<b>11,31</b>
<b>3PLZ175</b>	30x30x3,50	175	2,55	10	<b>13,19</b>
<b>3PLZ200</b>	35x35x4,00	200	3,60	5	<b>19,67</b>
<b>3PLZ225</b>	35x35x4,00	225	4,10	5	<b>22,06</b>
<b>3PLZ250</b>	35x35x4,00	250	4,50	5	<b>24,54</b>
<b>3PLZ300</b>	35x35x4,00	300	5,50	5	<b>29,53</b>

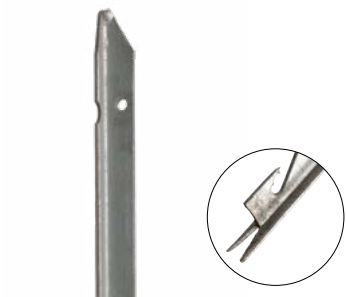

## PALI ZINCATI PESANTI

Articolo	T Sezione	↑ cm	kg pz.	Pz. fascio	€ cad.
<b>3PPZN130</b>	30x30x5,00	130	2,66	10	<b>13,92</b>
<b>3PPZN160</b>	30x30x5,00	160	3,35	10	<b>17,42</b>
<b>3PPZN182</b>	30x30x5,00	182	3,80	10	<b>19,80</b>
<b>3PPZN206</b>	35x35x5,50	206	5,80	5	<b>30,30</b>
<b>3PPZN235</b>	35x35x5,50	235	6,50	5	<b>33,94</b>
<b>3PPZN255</b>	35x35x5,50	255	7,10	5	<b>37,13</b>
<b>3PPZN295</b>	40x40x4,50	300	7,60	5	<b>40,55</b>

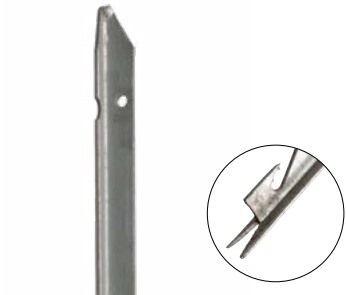

## SAETTE ZINCATE

Articolo	Per pali h	L Sezione	↑ cm	kg pz.	Pz. fascio	€ cad.
<b>3SZ120</b>	100-125-150	25x25	120	1,20	10	<b>7,86</b>
<b>3SZ150</b>	175	25x25	150	1,50	10	<b>9,85</b>
<b>3SZ200</b>	200-225-250	25x25	200	2,00	10	<b>13,09</b>

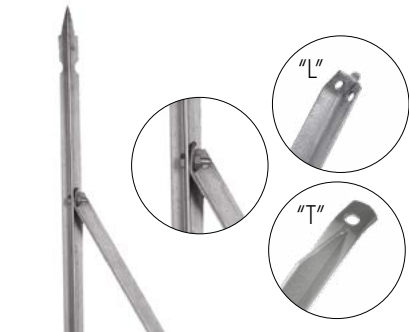

Articolo	Per pali h	T Sezione	↑ cm	Pz. fascio	€ cad.
<b>3SZT200</b>	200-225-250	30x3,5	200	10	<b>22,46</b>
<b>3SZT225</b>	225-250-300	30x3,5	225	10	<b>25,36</b>

# RECINZIONI

## DADI E BULLONI ZINCATI PER SAETTE INOX



Articolo	Misura	Confezione	€ cad.
<b>3BULLINOX</b>	8x25	10	<b>0,495</b>

## PALI A T A SBALZO

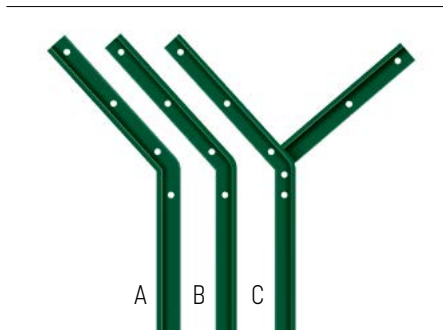

Descrizione	T Sezione	€ cad.
Pali a T pesanti plasticati a sbalzo	40-50	su richiesta
Pali a T pesanti zincati a sbalzo	40-50	su richiesta

## PALI A TUBO PLASTICATI CON PASSAFILO IN PLASTICA



Articolo	Ø mm	T Sezione		€ cad.
		cm	Passafili	
<b>3PTPP34120</b>	34	120	3	<b>11,27</b>
<b>3PTPP34150</b>	34	150	3	<b>13,91</b>
<b>3PTPP38175</b>	38	175	3	<b>17,87</b>
<b>3PTPP38200</b>	38	200	3	<b>20,47</b>
<b>3PTPP48200</b>	48	200	3	<b>25,47</b>
<b>3PTPP48230</b>	48	230	3	<b>29,27</b>
<b>3PTPP48260</b>	48	260	4	<b>33,16</b>
<b>3PTPP48300</b>	48	300	6	<b>38,17</b>

## SAETTE PLASTICATE PER PALI A TUBO CON PASSAFILO IN PLASTICA



Articolo	Ø mm	cm	€ cad.
<b>3SPTP34120</b>	34	120	<b>11,83</b>
<b>3SPTP34150</b>	34	150	<b>14,55</b>
<b>3SPTP38175</b>	38	175	<b>18,71</b>
<b>3SPTP38200</b>	38	200	<b>21,42</b>
<b>3SPTP48200</b>	48	200	<b>26,68</b>
<b>3SPTP48260</b>	48	260	<b>34,74</b>

## COLLARI PLASTICATI PER SAETTE



Articolo	 $\emptyset$ mm	€ cad.
<b>3COLLP34</b>	34	<b>1,84</b>
<b>3COLLP38</b>	38	<b>2,03</b>
<b>3COLLP48</b>	48	<b>2,24</b>
<b>3COLLP60</b>	60	<b>2,37</b>



## COLLARI ZINCATI A CALDO PER SAETTE A TUBO



Articolo	 $\emptyset$ mm		€ cad.
<b>3COLLZ48</b>	48	2,593	<b>2,463</b>
<b>3COLLZ60</b>	60	4,004	<b>4,180</b>

## CANCELLI PEDONALI "GREEN" VERDI





Articolo	 cm	 cm	 Piantane	€ cad.
<b>3CSP1000X1000</b>	100	100	60x60	<b>272,48</b>
<b>3CSP1000X1250</b>	100	125	60x60	<b>292,24</b>
<b>3CSP1000X1500</b>	100	150	60x60	<b>307,84</b>
<b>3CSP1000X1750</b>	100	175	60x60	<b>340,08</b>
<b>3CSP1000X2000</b>	100	200	60x60	<b>362,96</b>

Telaio  35/40 mm - Rete elettrosaldata  $\#$  50x50 mm  $\emptyset$  4 mm

## CANCELLI PEDONALI "GREEN" ANTRACITE



Articolo	 cm	 cm	 Piantane	€ cad.
<b>3CSAP1000X1000</b>	100	100	60x60	<b>349,92</b>
<b>3CSAP1000X1250</b>	100	125	60x60	<b>371,52</b>
<b>3CSAP1000X1500</b>	100	150	60x60	<b>392,04</b>
<b>3CSAP1000X1750</b>	100	175	60x60	<b>428,76</b>
<b>3CSAP1000X2000</b>	100	200	60x60	<b>567,57</b>

Telaio  35/40 mm - Rete elettrosaldata  $\#$  50x200 mm  $\emptyset$  5 mm

## CANCELLI DOPPI "GREEN"

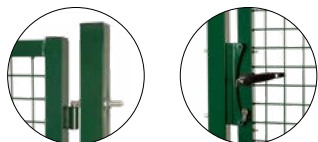

Articolo	cm	cm	Piantane	€ cad.
3CDP3000X1000	300	100	100x100	887,12
3CDP3000X1250	300	125	100x100	985,92
3CDP3000X1500	300	150	100x100	1.073,28
3CDP3000X1750	300	175	100x100	1.172,08
3CDP3000X2000	300	200	100x100	1.277,12
3CDP4000X1500	400	150	100x100	1.403,35
3CDP4000X1750	400	175	100x100	1.542,58
3CDP4000X2000	400	200	100x100	1.687,34

Telaio 35/40 mm - Rete elettrosaldata 50x50 mm Ø 4 mm

## CANCELLI PEDONALI ZINCATI



Articolo	cm	cm	Piantane	€ cad.
3CSZ1000X1000	100	100	60x60	479,52
3CSZ1000X1250	100	125	60x60	539,31
3CSZ1000X1500	100	150	60x60	586,44
3CSZ1000X1750	100	125	60x60	696,71
3CSZ1000X2000	100	200	60x60	719,28

Telaio 35/40 mm - Rete elettrosaldata 50x50 mm Ø 4 mm

## PASTRA ZINCATA E PLASTICATA

Articolo		Piantane	€ cad.
3GSZPQ60	zincata	60x60	18,57
3GSPPQ60	plasticata	60x60	23,86

## KIT SERRATURA

Articolo		€ cad.
3CSPKIT	per cancello singolo plasticato	120,96
3CDPKIT	per cancello doppio plasticato	324,00

## PANNELLO "GREEN" VERDE



Articolo	cm	cm	Sezione rete	Ø mm	Nervature	€ cad.
3GPAN50620	200	62	50x200	5	2	30,43
3GPAN50820	200	82	50x200	5	2	38,41
3GPAN51020	200	102	50x200	5	2	44,76
3GPAN51220	200	122	50x200	5	2	50,80
3GPAN51420	200	142	50x200	5	2	56,85
3GPAN51720	200	172	50x200	5	3	69,97
3GPAN51920	200	192	50x200	5	3	76,48

## PANNELLO "GREEN" ANTRACITE

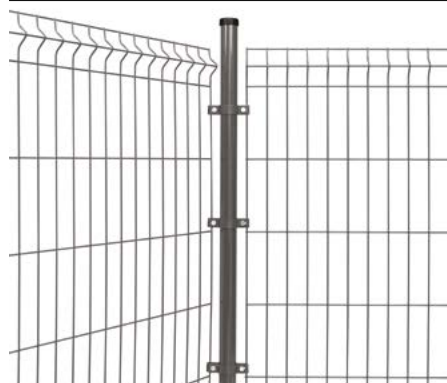

Articolo	→ cm	↑ cm	≡ Sezione rete	← Ø mm	Nervature	€ cad.
<b>3GPANA51030</b>	200	102	50x200	5	2	<b>47,00</b>
<b>3GPANA51230</b>	200	122	50x200	5	2	<b>53,36</b>
<b>3GPANA51430</b>	200	142	50x200	5	2	<b>59,73</b>
<b>3GPANA51730</b>	200	172	50x200	5	3	<b>73,56</b>
<b>3GPANA51930</b>	200	192	50x200	5	3	<b>80,39</b>

## PALI A TUBO PER PANNELLO "GREEN" VERDE



Articolo	↑ cm	← Ø mm	↑ cm*	↑ cm**	Collari o ganci consigliati	€ cad.
<b>3GPADSR1100</b>	110	48	62-82	102	3	<b>13,23</b>
<b>3GPADSR1300</b>	130	48	102	122	3	<b>15,62</b>
<b>3GPADSR1500</b>	150	48	122	142	3	<b>18,04</b>
<b>3GPADSR1800</b>	180	48	142	172	3	<b>20,65</b>
<b>3GPADSR2000</b>	200	48	172	192	4	<b>22,90</b>
<b>3GPADSR2300</b>	230	48	192	-	4	<b>26,29</b>
<b>3GPADSR2600</b>	260	48	192	-	4	<b>29,79</b>

\* Altezza del pannello con pali posati nel muretto o nel terreno

\*\* Altezza del pannello con pali posati usando piastra di supporto

Articolo	Descrizione	€ cad.
<b>A - 3GCOLPS</b>	Collari plasticati semplici Ø 48 mm + bullone	<b>2,76</b>
<b>B - 3GCOLPD</b>	Collari plasticati doppi Ø 48 mm + bullone	<b>3,96</b>
<b>C - 3GFPN</b>	Gancio di fissaggio in plastica nero per pali a tubo + viti	<b>2,07</b>
<b>D - 3GSZPT</b>	Piastra zincata di supporto per pali a tubo Ø 48 mm	<b>14,50</b>
<b>D1 - 3GSPPT</b>	Piastra plasticata di supporto per pali a tubo Ø 48 mm	<b>18,46</b>
<b>E - 3GBEZ</b>	Bulloni ad espansione per piastra supporto pali	<b>1,91</b>



A

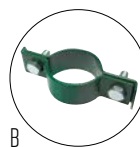

B



C



D



E

## PALI A TUBO PER PANNELLO "GREEN" ANTRACITE



Articolo	↑ cm	↖ mm	↑ cm*	↑ cm**	Collari o ganci consigliati	€ cad.
<b>3GPADSRA1100</b>	110	48	62-82	102	3	<b>13,88</b>
<b>3GPADSRA1300</b>	130	48	102	122	3	<b>16,40</b>
<b>3GPADSRA1500</b>	150	48	122	142	3	<b>18,94</b>
<b>3GPADSRA1750</b>	175	48	142	172	3	<b>21,65</b>
<b>3GPADSRA2000</b>	200	48	172	192	4	<b>24,02</b>
<b>3GPADSRA2300</b>	230	48	192	-	4	<b>27,60</b>
<b>3GPADSRA2600</b>	260	48	192	-	4	<b>31,27</b>

\* Altezza del pannello con pali posati nel muretto o nel terreno

\*\* Altezza del pannello con pali posati usando piastra di supporto

Articolo	Descrizione	€ cad.
<b>A - 3GCOLAS</b>	Collari plasticati semplici Ø 48 mm + bullone	<b>3,04</b>
<b>B - 3GCOLAD</b>	Collari plasticati doppi Ø 48 mm + bullone	<b>4,34</b>
<b>C - 3GFPN</b>	Gancio di fissaggio in plastica nero per pali a tubo + viti	<b>2,07</b>
<b>D - 3GSZPT</b>	Piastra zincata di supporto per pali a tubo Ø 48 mm	<b>14,50</b>
<b>E - 3GBEZ</b>	Bulloni ad espansione per piastra supporto pali	<b>1,91</b>

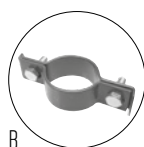

## BARRE DI TENSIONE TONDINO ZINCATO



Articolo	↖ mm	↔ cm	≡ Pz. fascio	€ cad.
<b>3TOND105</b>	8	105	10	<b>2,48</b>
<b>3TOND130</b>	8	130	10	<b>3,11</b>
<b>3TOND155</b>	8	155	10	<b>3,68</b>
<b>3TOND180</b>	8	180	10	<b>4,26</b>
<b>3TOND205</b>	8	205	10	<b>4,87</b>

## BARRE DI TENSIONE TONDINO PLASTICATO

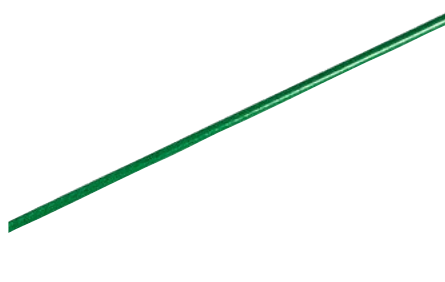

Articolo	↖ mm	↔ cm	≡ Pz. fascio	€ cad.
<b>3TONDP105</b>	7	105	10	<b>2,08</b>
<b>3TONDP130</b>	7	130	10	<b>2,57</b>
<b>3TONDP155</b>	7	155	10	<b>3,08</b>
<b>3TONDP180</b>	7	180	10	<b>3,54</b>
<b>3TONDP205</b>	7	205	10	<b>4,07</b>

# RECINZIONI

## PALI A TUBO QUADRO PER PANNELLO "GREEN" VERDE



Articolo	↑ cm	Sezione	↑ cm*	↑ cm**	Collari o ganci consigliati	€ cad.
<b>3GPADSQ1100</b>	110	50x50	62-82	102	3	<b>18,40</b>
<b>3GPADSQ1300</b>	130	50x50	102	122	3	<b>21,11</b>
<b>3GPADSQ1500</b>	150	50x50	122	142	3	<b>24,37</b>
<b>3GPADSQ1800</b>	180	50x50	142	172	3	<b>28,63</b>
<b>3GPADSQ2000</b>	200	50x50	172	192	4	<b>31,53</b>
<b>3GPADSQ2300</b>	230	50x50	192	-	4	<b>36,27</b>

\* Altezza del pannello con pali posati nel muretto o nel terreno

\*\* Altezza del pannello con pali posati usando piastra di supporto

Articolo	Descrizione	€ cad.
<b>A - 3GCOLQPS</b>	Collari plasticati semplici Ø 50 mm + bullone	<b>5,06</b>
<b>B - 3GCOLQPD</b>	Collari plasticati doppi Ø 50 mm + bullone	<b>5,48</b>
<b>C - 3GFPNQ</b>	Gancio di fissaggio in pvc nero per pali quadri + viti	<b>2,07</b>
<b>D - 3GSZPQ</b>	Piastra zincata di supporto per pali quadri 50x50 mm	<b>13,63</b>
<b>D1-3GSPPQ</b>	Piastra plasticata di supporto per pali quadri 50x50 mm	<b>17,36</b>
<b>E - 3GBEZ</b>	Bulloni ad espansione per piastra supporto pali	<b>1,91</b>

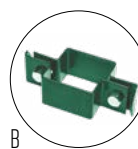
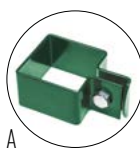

## PALI A TUBO QUADRO PER PANNELLO "GREEN" ANTRACITE



Articolo	↑ cm	Sezione	↑ cm*	↑ cm**	Collari o ganci consigliati	€ cad.
<b>3GPADSQA1100</b>	110	50x50	62-82	102	3	<b>19,31</b>
<b>3GPADSQA1300</b>	130	50x50	102	122	3	<b>22,15</b>
<b>3GPADSQA1500</b>	150	50x50	122	142	3	<b>25,55</b>
<b>3GPADSQA1800</b>	180	50x50	142	172	3	<b>30,08</b>
<b>3GPADSQA2000</b>	200	50x50	172	192	4	<b>33,11</b>
<b>3GPADSQA2300</b>	230	50x50	192	-	4	<b>38,12</b>

\* Altezza del pannello con pali posati nel muretto o nel terreno

\*\* Altezza del pannello con pali posati usando piastra di supporto

Articolo	Descrizione	€ cad.
<b>A - 3GCOLQAS</b>	Collari plasticati semplici Ø 50 mm + bullone	<b>5,56</b>
<b>B - 3GCOLQAD</b>	Collari plasticati doppi Ø 50 mm + bullone	<b>6,03</b>
<b>C - 3GFPNQ</b>	Gancio di fissaggio in pvc nero per pali quadri + viti	<b>2,07</b>
<b>D - 3GSZPQ</b>	Piastra zincata di supporto per pali quadri 50x50 mm	<b>13,63</b>
<b>E - 3GBEZ</b>	Bulloni ad espansione per piastra supporto pali	<b>1,91</b>

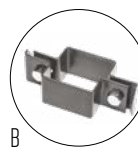
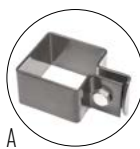

# RECINZIONI

## TENDIFILO



Articolo	→ cm	📦 Pz. scatola	€ cad.
<b>3TP100 plasticati verde</b>	10	100	<b>1,000</b>
<b>3TPA100 plasticati antracite</b>	10	100	<b>1,212</b>
<b>3TZ100 zincati</b>	10	100	<b>1,040</b>

## FILO SPINATO



Articolo	📏 Ø mm	N° punte	Distanze punte cm	→ ml	🏋️ kg pz.	€ cad.
<b>3FSZ zincato</b>	1,70	4	10	100	5,10	<b>40,50</b>
Prodotto con fili d'acciaio ad alta resistenza con carico di rottura pari a 440 kg min. (equivalente a quello di un filo di acciaio dolce Ø 2,70). Confezionato in scatole di cartone.						
<b>3FSP plasticato</b>	2,20/2,80	4	10	100	10	<b>42,10</b>

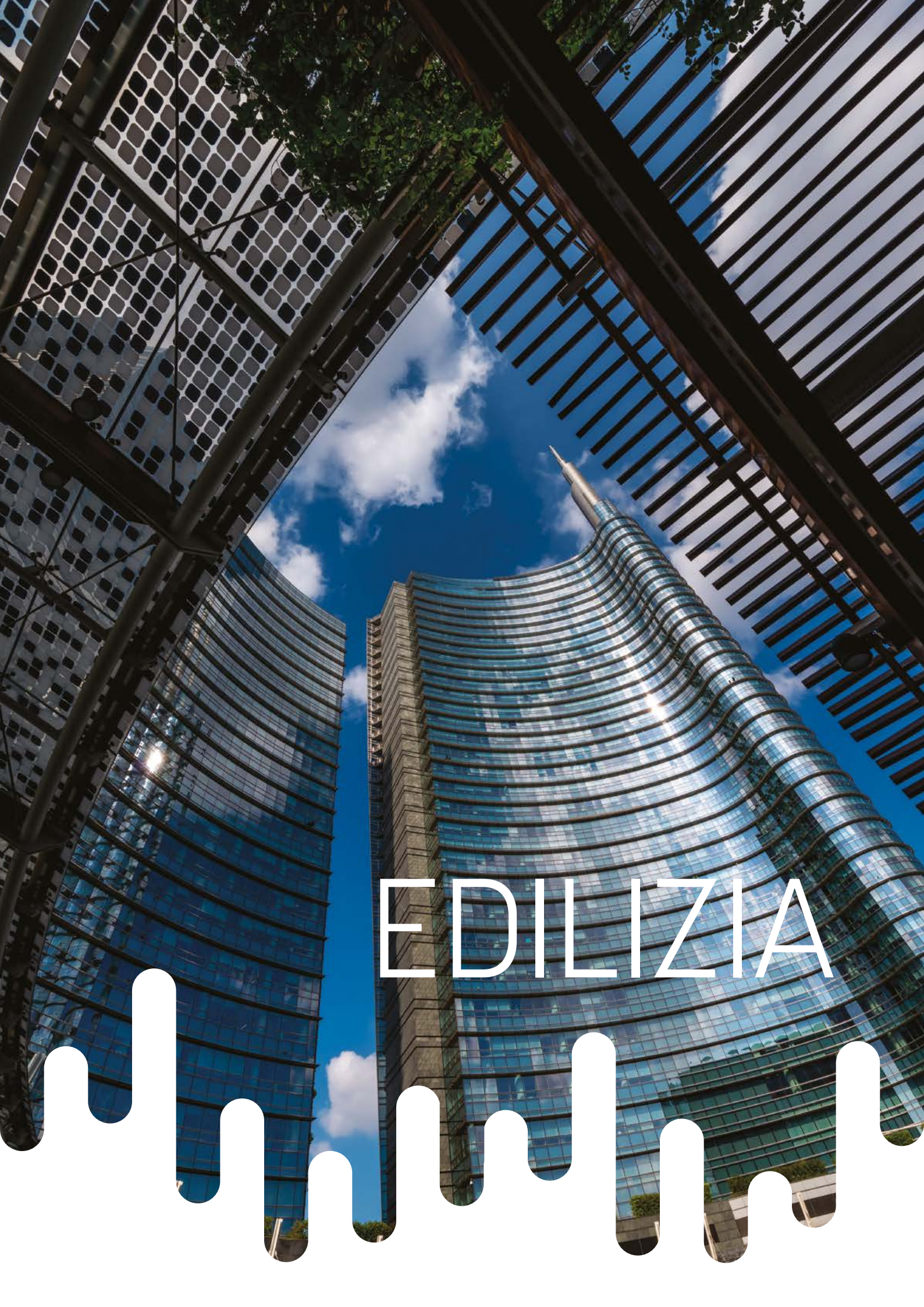





# EDILIZIA



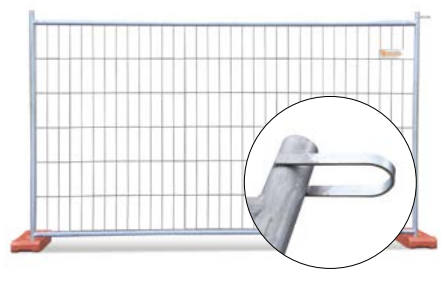

## YARDNET PESANTE





Articolo	Ø Tubo orizz. mm	Ø Tubo vert. mm	Ø Filo rete mm	mm 	kg pz. 	Pacchi 	€ cad.
<b>2CANMOB</b>	40	40	3,50	3500x2000	18,00	25	<b>62,60</b>
<b>2CANMOB22</b>	40	40	3,50	2000x2000	12,70	25	<b>56,87</b>
<b>2CANMOB1</b>	40	40	3,50	3500x1100	13,00	25	<b>53,48</b>
<b>2CANMOBAR</b>	40	40	3,50	misure varie	-	-	su richiesta

Misure comprensive di gancio di congiunzione

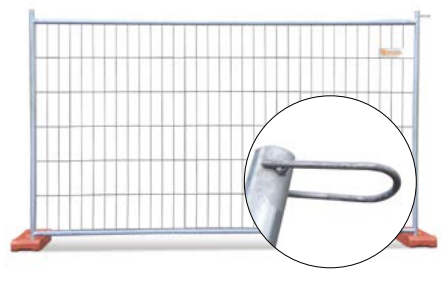
## YARDNET MEDIA





Articolo	Ø Tubo orizz. mm	Ø Tubo vert. mm	mm 	kg pz. 	pacchi 	€ cad.
<b>2CANMOBME</b>	40	40	3500x2000	14,50	30	<b>47,68</b>

Misure comprensive di gancio di congiunzione

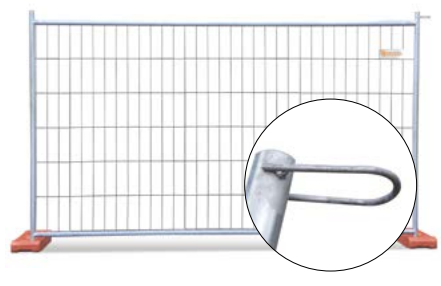
## YARDNET ECONOMICA





Articolo	Ø Tubo orizz. mm	Ø Tubo vert. mm	mm 	kg pz. 	pacchi 	€ cad.
<b>2CANMOBTECO</b>	30	40	3500x2000	12	35	<b>43,08</b>
<b>2CANMOBU100TECO</b>	30	40	3500x1000	8	35	<b>40,99</b>
<b>2CANMOBTECO2</b>	30	40	2000x2000	9	35	<b>42,37</b>

Misure comprensive di gancio di congiunzione

## YARDGATE



Articolo	Ø Tubo orizz. mm	Ø Tubo vert. mm	Ø Filo rete mm	mm 	kg pz. 	€ cad.
<b>2CANCP</b>	40	40	3,50	1200x2000	9,75	<b>44,09</b>
<b>2CANMOBP</b>	40	40	3,50	3500x2000	25,5	<b>144,25</b>

Misure comprensive di gancio di congiunzione



## MINIPLINT



Articolo	Descrizione	mm	kg pz.	pz. per bancale	€ cad.
<b>3PLI</b>	Cemento	680x220x130	27,90	25	<b>7,965</b>
<b>3PLIP</b>	Cemento + plastica	680x240x100	25,00	40	<b>11,704</b>
<b>3PLIPECO</b>	Gomma nero ecologica	667x235x140	26,00	20	<b>22,800</b>

## CONTENITORE RETE YARDNET



Descrizione	pz.	€ cad.
Contenitore rete Yardnet	25	<b>715,810</b>

## YARDNET TONDE

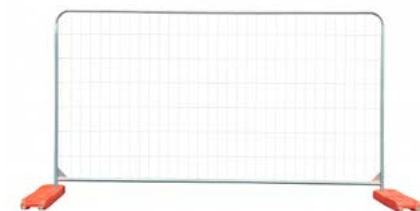

Articolo	Ø Tubo orizz. mm	Ø Tubo vert. mm	Ø Filo rete mm	mm	€ cad.
<b>3CANTONDE</b>	40	40	3,2/2,2	3500x2000	<b>61,43</b>

## CARTELLI E ACCESSORI



Articolo	Descrizione	mm	€ cad.
<b>3CPERS</b>	Cartelli personalizzati	200x100	su richiesta
<b>3CAV</b>	Cartelli alta visibilità	820x100	su richiesta
<b>3MXCM</b>	Morsetto di congiunzione per Yardnet		<b>3,420</b>
<b>3CXCM</b>	Cerniera per Yardgate		<b>29,70</b>
<b>2CANMSZY</b>	Saetta zincata per sostegno Yardnet		<b>16,28</b>
<b>3RXCM</b>	Ruota per Yardgate		<b>26,32</b>





## TRANSENNE

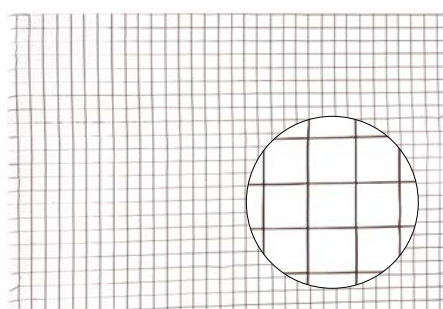

Articolo	Ø Tubo orizz. mm	Ø Tubo vert. mm	mm	€ cad.
<b>3TRAN</b>	38	12	2300x1100	<b>67,53</b>

## RETE ELETTRICALDATA PER PLAFONI





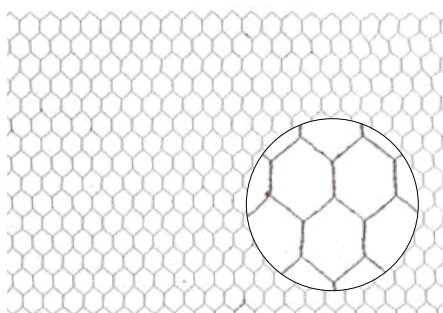

Articolo		 Ø mm	 kg/m <sup>2</sup>	 ml	€ mq
<b>A) 3PF1212</b>	12x12	0,65	0,450	25	su richiesta
<b>B) 3PFZ1225</b>	12x25	0,65	0,300	25	su richiesta

A) Finitura: lucida - B) Finitura: zincata





## TORSIONET ZINCATA DOPO

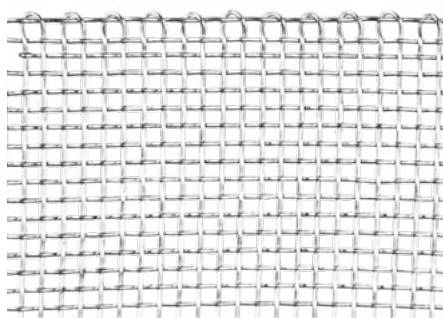

Articolo		 Ø mm	 kg/m <sup>2</sup>	 ml	€ mq
<b>3TRIZ132</b>	13	0,700	0,475	50	<b>4,55</b>
<b>3TRIZ162</b>	16	0,700	0,310	50	<b>3,51</b>
<b>3TRIZ192</b>	19	0,700	0,250	50	<b>2,73</b>
<b>3TRIZ253</b>	25	0,800	0,220	50	<b>2,42</b>
<b>3TRIZ514</b>	51	0,900	0,230	50	<b>2,05</b>
<b>3TRIZ516</b>	51	1,100	0,260	50	<b>2,37</b>
<b>3TRIZ517</b>	51	1,200	0,350	50	<b>2,86</b>





## TEXILNET TESSUTA ZINCATA CON CIMOSSA



Articolo		 Ø mm	 kg/m <sup>2</sup>	 ml	€ kg
<b>3TEX11</b>	1x1	0,60	2,300	25	<b>7,88</b>
<b>3TEX22</b>	2x2	0,70	2,250	25	<b>7,88</b>
<b>3TEX33</b>	3x3	0,80	2,250	25	<b>7,63</b>
<b>3TEX44</b>	4x4	0,90	2,220	25	<b>7,63</b>
<b>3TEX55</b>	5x5	1,00	2,200	25	<b>7,63</b>

## RETE PARAMASSI





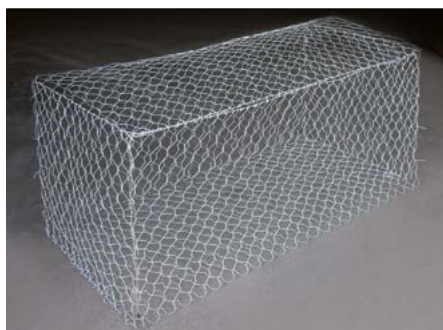

Articolo		 Ø mm	 cm	 ml	 kg/m <sup>2</sup>	€ mq
<b>3TRI8116</b>	8x10	2,70	200	50	1,4	<b>6,37</b>
<b>3TRI8117</b>	8x10	3,00	200	50	1,75	<b>7,67</b>

Finitura: forte zincata gr 245 mq ca. - Per altezze diverse da cm 200 chiedere preventivo.

## GABBIONI PER ARGINI





Articolo		 Ø mm	 Dimensioni	 kg pz.	€ cad.
<b>3GAB270</b>	8x10	2,70	2x1x1	15,40	<b>63,70</b>
<b>3GAB300</b>	8x10	3,00	2x1x1	19,20	<b>87,10</b>

Finitura: forte zincata gr 245 mq ca. - Per dimensioni diverse da 2x1x1 chiedere preventivo.





## EASYPAN



Articolo	Descrizione	 Ø mm	 kg foglio	 pz. per bancale	€ cad.
<b>3Z2X1C</b>	Piana	1,60	0,95	700	<b>2,997</b>
<b>3Z2X1A</b>	Con impronta	1,80	1,30	600	<b>4,428</b>
<b>3Z2X1B</b>	Piana	1,80	1,30	600	<b>4,428</b>
<b>3Z2X1G</b>	Con impronta	2,00	1,62	500	<b>5,805</b>
<b>3Z2X1L3</b>	Piana	3,00	4,28	200	<b>18,750</b>

Finitura: zincata a caldo - Legati a fasci da 20 fogli

Pannelli per sottofondi

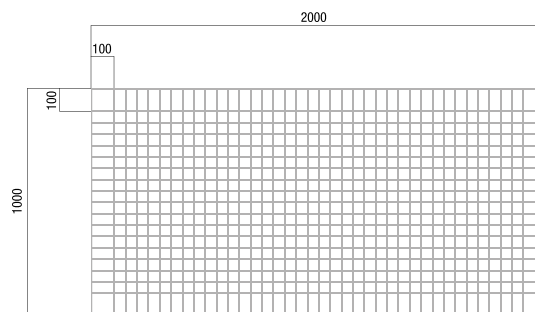
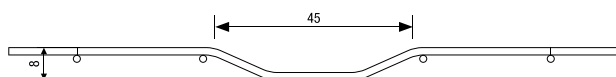

Articolo	Descrizione		 Ø mm	 mm	 pz. per bancale	€ cad.
<b>3Z2X1P</b>	piana	100x100	3,00	2100x1200	300	<b>11,799</b>



Maglia 50x50 - Perimetro 100x50

## PANNELLI ZINCATI 2000x1000



**I.MA.FER.**

Articolo	Descrizione	 Ø mm	 kg foglio	 pz. per bancale	€ cad.
4Z2X1A	Con impronta	1,80	1,25	400-700	non disponibili
4Z2X1B	Piana	1,80	1,20	400-700	non disponibili
4Z2X1G	Con impronta	1,60	1,00	400-700	non disponibili
4Z2X1F	Piana	1,60	1,00	400-700	non disponibili
4Z2X1L	Piana	1,45	0,86	800	non disponibili

Quantità e prezzo secondo disponibilità

## DISTANZIATORI STANDARD





Articolo	 cm	 Nastro mm	 Pz. confezione	€ cad.
2DIS010	10	20x1,80	100	0,1717
2DIS015	15	20x1,80	100	0,2090
2DIS020	20	20x1,80	100	0,2463
2DIS025	25	20x1,80	100	0,2837
2DIS030	30	20x1,80	100	0,3210
2DIS035	35	20x1,80	100	0,3583
2DIS040	40	20x1,80	100	0,3956
2DIS045	45	20x1,80	100	0,4330
2DIS050	50	20x1,80	100	0,4703
2DIS055	55	20x1,80	100	0,5076
2DIS060	60	20x1,80	100	0,5449
2DIS065	65	20x1,80	100	0,5823
2DIS070	70	20x1,80	100	0,6196
2DIS075	75	20x1,80	100	0,6569
2DIS080	80	20x1,80	100	0,6941
2DIS085	85	20x1,80	100	0,7316
2DIS090	90	20x1,80	100	0,7686
2DIS095	95	20x1,80	100	0,8062
2DIS100	100	20x1,80	100	0,8435
2DIS110	110	20x1,80	50	0,9535
2DIS120	120	20x1,80	50	1,0310
2DIS130	130	20x1,80	50	1,1085
2DIS140	140	20x1,80	50	1,1861
2DIS150	150	20x1,80	50	1,2636

Su richiesta si producono misure diverse - Per misure intermedie riferirsi al prezzo della misura superiore

## DISTANZIATORI IN CEMENTO



Articolo	 mm	 Pz. confezione	€ cad.
3DISCEM20	20	440	0,168
3DISCEM25	25	325	0,196
3DISCEM30	30	295	0,207
3DISCEM40	40	185	0,286
3DISCEM50	50	150	0,336

## CUNEI PER DISTANZIATORI



Articolo	Descrizione	Pz. scatola	€ cad.
<b>3CUNEIG</b>	grandi	100	<b>0,4060</b>
<b>3CUNEIP</b>	piccoli	100	<b>0,2184</b>

## REGGETTA FORATA



Articolo	mm	Spessore mm	€ kg
<b>3REGFOR</b>	20	1,00	<b>6,500</b>

## REGGETTA DENTATA



Articolo	mm	Spessore mm	€ kg
<b>3REGDENT</b>	20	1,00	<b>5,980</b>

## REGGETTA LUCIDA



Articolo	mm	Spessore mm	€ kg
<b>3REGL10</b>	10	0,40	<b>2,41</b>
<b>3REGL13</b>	13	0,45-0,50	<b>2,30</b>
<b>3REGL16</b>	16	0,50-0,60	<b>2,26</b>
<b>3REGL196</b>	19	0,60-0,70	<b>2,25</b>
<b>3REGL25</b>	25	0,80-0,90	<b>2,28</b>

Su richiesta si producono misure diverse

## PALI PER MESSA A TERRA

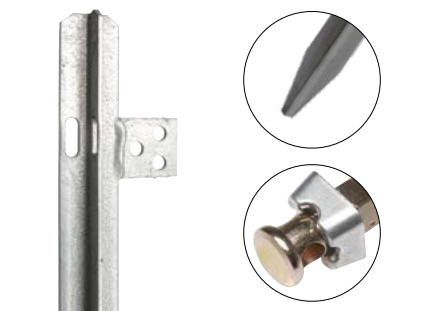

Articolo	Dimensioni	mm	kg pz.	€ cad.
<b>3MESSAT100</b>	50x50x5	100	3,50	<b>19,59</b>
<b>3MESSAT150</b>	50x50x5	150	5,21	<b>29,38</b>
<b>3MESSAT200</b>	50x50x5	200	7,00	<b>39,19</b>
<b>3MORS</b>	morsetto semplice per cavo rame			<b>2,73</b>

Finitura: zincati a caldo

## LEGACCI FILO COTTO BIANCO



Articolo	mm	Ø mm	Pz. fascio	Conf. sacco	€ cad.
<b>2LEG110080</b>	80	1,10	2.000	20.000	<b>0,00676</b>
<b>2LEG110100</b>	100	1,10	2.000	20.000	<b>0,00734</b>
<b>2LEG110120</b>	120	1,10	2.000	20.000	<b>0,00792</b>
<b>2LEG110140</b>	140	1,10	2.000	20.000	<b>0,00849</b>
<b>2LEG110160</b>	160	1,10	2.000	20.000	<b>0,00907</b>
<b>2LEG110180</b>	180	1,10	2.000	10.000	<b>0,00964</b>
<b>2LEG110200</b>	200	1,10	2.000	10.000	<b>0,01022</b>
<b>2LEG110220</b>	220	1,10	2.000	10.000	<b>0,01080</b>
<b>2LEG110240</b>	240	1,10	2.000	10.000	<b>0,01137</b>
<b>2LEG110260</b>	260	1,10	2.000	10.000	<b>0,01195</b>
<b>2LEG110280</b>	280	1,10	2.000	10.000	<b>0,01252</b>
<b>2LEG110300</b>	300	1,10	2.000	10.000	<b>0,01310</b>

Su richiesta fascio da 1000 pezzi

## LEGACCI IN FILO ZINCATO







Articolo	mm	Ø mm	Pz. fascio	Conf. sacco	€ cad.
<b>2LEGZ080</b>	80	1,10	2.000	20.000	<b>0,00863</b>
<b>2LEGZ100</b>	100	1,10	2.000	20.000	<b>0,00936</b>
<b>2LEGZ120</b>	120	1,10	2.000	20.000	<b>0,01009</b>
<b>2LEGZ140</b>	140	1,10	2.000	20.000	<b>0,01081</b>
<b>2LEGZ160</b>	160	1,10	2.000	20.000	<b>0,01153</b>
<b>2LEGZ180</b>	180	1,10	2.000	10.000	<b>0,01226</b>
<b>2LEGZ200</b>	200	1,10	2.000	10.000	<b>0,01298</b>
<b>2LEGZ220</b>	220	1,10	2.000	10.000	<b>0,01371</b>
<b>2LEGZ240</b>	240	1,10	2.000	10.000	<b>0,01443</b>
<b>2LEGZ260</b>	260	1,10	2.000	10.000	<b>0,01516</b>
<b>2LEGZ280</b>	280	1,10	2.000	10.000	<b>0,01588</b>
<b>2LEGZ300</b>	300	1,10	2.000	10.000	<b>0,01661</b>

Su richiesta fascio da 1000 pezzi

## LEGACCI IN FILO PLASTICATO

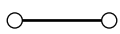

Articolo	 ml	 Ø mm	 Pz. fascio	 Conf. sacco	€ cad.
<b>2LEGPV080</b>	80	1,00/1,70	2.000	20.000	<b>0,01309</b>
<b>2LEGPV100</b>	100	1,00/1,70	2.000	20.000	<b>0,01428</b>
<b>2LEGPV120</b>	120	1,00/1,70	2.000	20.000	<b>0,01547</b>
<b>2LEGPV140</b>	140	1,00/1,70	2.000	20.000	<b>0,01665</b>
<b>2LEGPV160</b>	160	1,00/1,70	2.000	20.000	<b>0,01784</b>
<b>2LEGPV180</b>	180	1,00/1,70	2.000	10.000	<b>0,01903</b>
<b>2LEGPV200</b>	200	1,00/1,70	2.000	10.000	<b>0,01309</b>
<b>2LEGPV220</b>	220	1,00/1,70	2.000	10.000	<b>0,01309</b>
<b>2LEGPV240</b>	240	1,00/1,70	2.000	10.000	<b>0,01309</b>
<b>2LEGPV260</b>	260	1,00/1,70	2.000	10.000	<b>0,01309</b>
<b>2LEGPV280</b>	280	1,00/1,70	2.000	10.000	<b>0,01309</b>
<b>2LEGPV300</b>	300	1,00/1,70	2.000	10.000	<b>0,01309</b>

Su richiesta fascio da 1000 pezzi

## TORCITORI



Articolo	Descrizione	€ cad.
<b>3TORA</b>	Automatici	<b>39,00</b>
<b>3TORM</b>	Manuale	<b>15,60</b>

## CARRIOLA



Articolo	Descrizione	Spessore vasca	 kg pz.	€ cad.
<b>3CTL</b>	carriola leggera r/vespa	.8/10	12,50	<b>74,88</b>
<b>3CTP</b>	carriola pesante r/vespa	.10/10	14,00	<b>79,82</b>
<b>3CTPA</b>	carriola pesante in angolare r/vespa	.10/10	16,00	<b>107,25</b>
<b>3CTR</b>	carriola tipo ribaltabile	.10/10	15,00	<b>108,16</b>
<b>3CTRP</b>	ruota per carriola piena	-	-	<b>32,11</b>
<b>3CTRV</b>	ruota per carriola vespa	-	-	<b>26,00</b>
<b>3CVL</b>	vasca per carriola leggera	.8/10	-	<b>25,74</b>
<b>3CVP</b>	vasca per carriola pesante	.10/10	-	<b>30,03</b>
<b>3CVR</b>	vasca per carriola ribaltabile	.10/10	-	<b>34,32</b>
<b>3CA</b>	camera d'aria	-	-	<b>8,58</b>

Finitura: vernice all'acqua - Bordo antinfortunistico

# CONDIZIONI GENERALI DI VENDITA

I prezzi del presente listino non sono impegnativi, in quanto possono variare in qualsiasi momento e senza preavviso, secondo il costo della mano d'opera e le oscillazioni di prezzo delle materie prime.

I pagamenti dovranno essere effettuati nei termini e nelle condizioni stabilite al momento dell'ordine. In caso di mancato rispetto delle scadenze riportate in fattura, il cliente accetta interessi pari al tasso ufficiale "BCE" maggiorato di 8 punti percentuali (riferimento decreto N. 231/2002 e successive modifiche) più eventuali spese bancarie.

In caso di mancato pagamento di una fattura, previa messa in mora rimasta senza effetto oltre i termini di 5 giorni, la società si riserva il diritto di sospendere tutte le consegne in corso o future.

Le caratteristiche dei prodotti elencati, così come i pesi e dimensioni, sono da ritenersi puramente indicativi e soggetti a tolleranze di produzione; possono subire variazioni e migliorie senza preavviso e senza che ciò possa essere oggetto di reclamo e/o variazione di prezzo.

La merce viaggia sempre a rischio e pericolo dell'acquirente, anche se venduta in porto franco. I prodotti devono essere controllati dal cliente al momento della consegna. Qualsiasi reclamo o contestazione riguardante difetti o mancanze, deve essere comunicata entro 5 giorni dalla data di consegna. I resi, in ogni caso, dovranno essere autorizzati e accompagnati da documento di trasporto. In caso di controversia il Foro competente è sempre quello di Lecco.

## CONDIZIONI GENERALI DI CONSEGNA

I prezzi sono intesi franco nostra fabbrica. La società si impegna a rispettare i tempi di consegna indicati nell'ordine, salvo forza maggiore e in caso di circostanze al di fuori del suo controllo (rottura di macchinari, difficoltà di approvvigionamenti, scioperi interni, scioperi degli autotrasportatori, situazioni climatiche impreviste, etc.) senza che questo sia motivo di annullamento degli ordini e richiesta di penalità.

## PER CONSEGNARE CON NOSTRI MEZZI O VETTORI

**Regione: Lombardia - Piemonte**

Addebito in fattura di una percentuale pari al **4%** dell'imponibile, nel caso tale percentuale non raggiungesse la tariffa minima di **€ 40**, in fattura sarà addebitata quest'ultima.

## MINIMO FATTURABILE

**Regione: Lombardia - Piemonte**

Il minimo fatturabile mensile è di **€ 500,00** (imponibile). Per fatturazioni inferiori a tale importo lo sconto base sarà diminuito del 5%.

**Regione: tutte le restanti**

Il minimo fatturabile è di **€ 1.000,00** (imponibile). Il costo del trasporto è variabile in funzione dell'imponibile.

**TRAFILERIE VAVASSORI** srl

via Prada, 21  
23883 Beverate di Brivio (LC)  
ITALY

T **+39 039 5320800**

F +39 039 5320583

commerciale@trafilerievavassori.it

**[www.trafilerievavassori.it](http://www.trafilerievavassori.it)**